

**Agilent Technologies**  
**Z5623A Option H84**  
User's and Service Guide



# **Agilent Technologies Z5623A Option H84**

## **User's and Service Guide**



**Agilent Technologies**

**Manufacturing Part Number: Z5623-90066**

**Printed in USA**

**August 2005**

© Copyright 2005 Agilent Technologies, Inc. All rights reserved.

---

## Warranty Statement

THE MATERIAL CONTAINED IN THIS DOCUMENT IS PROVIDED “AS IS,” AND IS SUBJECT TO BEING CHANGED, WITHOUT NOTICE, IN FUTURE EDITIONS. FURTHER, TO THE MAXIMUM EXTENT PERMITTED BY APPLICABLE LAW, AGILENT DISCLAIMS ALL WARRANTIES, EITHER EXPRESS OR IMPLIED WITH REGARD TO THIS MANUAL AND ANY INFORMATION CONTAINED HEREIN, INCLUDING BUT NOT LIMITED TO THE IMPLIED WARRANTIES OF MERCHANTABILITY AND FITNESS FOR A PARTICULAR PURPOSE. AGILENT SHALL NOT BE LIABLE FOR ERRORS OR FOR INCIDENTAL OR CONSEQUENTIAL DAMAGES IN CONNECTION WITH THE FURNISHING, USE, OR PERFORMANCE OF THIS DOCUMENT OR ANY INFORMATION CONTAINED HEREIN. SHOULD AGILENT AND THE USER HAVE A SEPARATE WRITTEN AGREEMENT WITH WARRANTY TERMS COVERING THE MATERIAL IN THIS DOCUMENT THAT CONFLICT WITH THESE TERMS, THE WARRANTY TERMS IN THE SEPARATE AGREEMENT WILL CONTROL.

---

## DFARS/Restricted Rights Notice

If software is for use in the performance of a U.S. Government prime contract or subcontract, Software is delivered and licensed as “Commercial computer software” as defined in DFAR 252.227-7014 (June 1995), or as a “commercial item” as defined in FAR 2.101(a) or as “Restricted computer software” as defined in FAR 52.227-19 (June 1987) or any equivalent agency regulation or contract clause. Use, duplication or disclosure of Software is subject to Agilent Technologies’ standard commercial license terms, and non-DOD Departments and Agencies of the U.S. Government will receive no greater than Restricted Rights as defined in FAR 52.227-19(c)(1-2) (June 1987). U.S. Government users will receive no greater than Limited Rights as defined in FAR 52.227-14 (June 1987) or DFAR 252.227-7015 (b)(2) (November 1995), as applicable in any technical data.

---

## Safety Notes

The following safety notes are used throughout this manual. Familiarize yourself with each of the notes and its meaning before operating this instrument. All pertinent safety notes for using this product are located in [Chapter 2, “Safety and Regulatory Information,”](#) on page 66.

---

**WARNING**      **Warning denotes a hazard. It calls attention to a procedure which, if not correctly performed or adhered to, could result in injury or loss of life. Do not proceed beyond a warning note until the indicated conditions are fully understood and met.**

---

---

**CAUTION**      Caution denotes a hazard. It calls attention to a procedure that, if not correctly performed or adhered to, could result in damage to or destruction of the instrument. Do not proceed beyond a caution sign until the indicated conditions are fully understood and met.

---

---

## Definitions

- *Specifications* describe the performance of parameters covered by the product warranty (temperature - 0 to 55 °C, unless otherwise noted.)
- *Typical* describes additional product performance information that is not covered by the product warranty. It is performance beyond specification that 80% of the units exhibit with a 95% confidence level over the temperature range 20 to 30 °C. Typical performance does not include measurement uncertainty.
- *Nominal* values indicate expected performance, or describe product performance that is useful in the application of the product, but is not covered by the product warranty.



---

# Contents

## Z5623A H84

Description .....	2
Verifying the Shipment .....	4
General Information .....	5
Video Feedthrough .....	6
Electrical Preparations .....	7
Environmental Preparations .....	9
Electrostatic Discharge Protection .....	10
Test Set Familiarization .....	11
Front Panel .....	11
Rear Panel .....	12
Operation Overview .....	14
System Setup .....	17
Controlling the Test Set .....	22
Commands .....	22
Typeface Key Conventions .....	22
PNA Control .....	23
Addressing Directly .....	24
Parallel Port .....	28
Direct Control .....	29
Controlling the Switches .....	29
Switch Indicators .....	29
Switch Indicator Function .....	31
Controlling the Attenuators .....	32
Making High Power Measurements With Option H84 .....	35
Setup .....	35
Determining Power Levels .....	37
Selecting Power Ranges and Attenuator Settings .....	39
Test Set Internal Configurations .....	45
Bypass .....	45
High Power .....	46
Pulse .....	46
Pulse High Power .....	47
Amplifier Terminate .....	47
Specification .....	48
Pulsed RF PIN Switch Detectors .....	48
E8363B/E8364B RF PIN Switch Modulator .....	48
Test Set Performance Verification .....	50
Procedure .....	51
Replaceable Parts .....	63

## Safety and Regulatory Information

Safety and Regulatory Information .....	66
Introduction .....	66
Connector Care and Cleaning .....	66
Before Applying Power .....	66
Shipping Instructions .....	66
Compliance with Canadian EMC Requirements .....	66
Compliance with German Noise Requirements .....	67
Declaration of Conformity .....	67
Statement of Compliance .....	67
Warnings .....	68
Cautions .....	69
Instrument Markings .....	70
Contacting Agilent .....	71



---

**Z5623A H84**

## Description

The [Agilent Technologies Z5623A Option H84](#) is a 2 GHz to 40 GHz Dual Directional Pulse Test Set. When connected to the E8363B or E8364B PNA Series Network Analyzer with option H08 (Pulse) and H11 (IF access), pulse measurements for both the forward and reverse parameters from 2 GHz to 40 GHz can be made depending on the PNA and Band Pass filter. The [Agilent Technologies Z5623A Option H84](#) can be configured in many ways. The Bypass configuration allows the user to use the E8363B or E8364B PNA Series Network Analyzer from 10 MHz to 50 GHz depending on the analyzer. This mode bypasses the test sets internal 2 GHz to 40 GHz PIN modulator switch. In the pulse mode the user can configure the test set for their application needs to either make straight un-conditioned pulse measurements or permit the insertion of high power amplifiers and other signal conditioning equipment to allow high power measurements at RF levels up to 20 Watts (+43 dBm) from 10 MHz to 40 GHz and 10 Watts (+40 dBm) from 40 GHz to 50 GHz.

Control of the [Agilent Technologies Z5623A Option H84](#) Dual Directional pulse test set can be performed either by GPIB or directly. Both methods control the port 1 and port 2 internal switches and attenuators. Direct control requires the user to connect to the two 37-pin D-sub connectors located on the rear panel. Both GPIB and direct control cannot be used simultaneously. When used in the direct control mode, the test sets front panel LCD indicator may differ from the user setup.

High power configurations require that attenuators and isolators be connected to the test ports and receivers to protect the E8363B or E8364B PNA Series Network Analyzer. The Agilent E8363BH85 and E8364BH85 High Power Configurable PNA Series Network Analyzer when ordered with the Option H08 and H11 can be used for high power pulse measurement applications. More information on the setup and configuration of the Agilent E8363BH85 and E8364BH85 PNA Series Network Analyzer can be found in manual p/n E8364-90027 Microwave PNA Series High Power Configurable Test Set Option H85.

The instrument is shipped from the factory with jumper cables installed on the front panel in what is called the Shipped Configuration. See [Figure 1-10 on page 16](#).

Two types of Band Pass filters are shipped with the Test Set. The band pass filters are used externally. The filters are used to eliminate video feedthrough from the PIN switch. The filters are banded. The low frequency filter (Z5623-80027) allows pulse measurements between 2 GHz to 20 GHz. The high frequency band pass filter (Z5623-80042) allows pulse measurements between 20 GHz and 40 GHz. See [“System Setup” on page 17](#).

The pulse test set can be used from 400 MHz to 2 GHz but is not specified. No band pass filters are provided for this range. If pulse measurements below 2 GHz, the user must provide an appropriate high pass filter for that band.

**Description**

If any pulse measurements are required using a frequency band that includes frequencies above and below 20 GHz, the user must supply a bandpass filter for that band or make two separate measurements.

Install the instrument so that the ON/OFF switch is readily identifiable and is easily reached by the operator. The ON/OFF switch or the detachable power cord is the instrument disconnecting device; it disconnects the mains circuit from the mains supply before other parts of the instrument. Alternatively, an externally installed switch or circuit breaker (which is readily identifiable and is easily reached by the operator) may be used as a disconnecting device.

---

## Verifying the Shipment

After the test set has been unpacked, keep the original packaging materials so they can be used if you need to transport the instrument.

Check the items received against [Table 1-1](#) to make sure you have received everything.

Inspect the test set and all accessories for any signs of damage that may have occurred during shipment. If your test set or any accessories appear to be damaged or missing, refer to [“Contacting Agilent” on page 71](#).

**Table 1-1**      **Content List**

Description	Agilent Part Number	Qty
0955-0608	μ-Wave Term 40 GHz, 1 Watt	4
1250-2330	3.5 mm M to 2.4 mm M Adapter	2
5063-9226	Kit — Front Handles	1
5063-9232	Kit — Rack Mount	1
5063-9803	RCVR Jumper	4
5063-9804	Source In Jumper	4
5063-9805	CPLR THRU Jumper	2
E8364-20059	Front Panel Jumper (attached)	6
Z5623-20519	Coaxial Cable (2.4 - 3.5 male, 6 in)	2
Z5623-60202	37-Pin D-SUB Jumper	2
Z5623-80027	2-20 GHz (highpass filter)	2
Z5623-80042	20-40 GHz (bandpass filter)	2
Z5623-90066	User’s and Service Guide	1
Power Cord	See <a href="#">Figure 1-3 on page 8</a>	1

## General Information

### Environmental:

Operating Temperature Range	0 to 55 °C
Non-Operating Temperature Range	-40 to 70 °C
Operating Humidity Range	Maximum relative humidity 80% for temperatures up to 31 °C decreasing linearly to 50% relative humidity at 40 °C (unless specified otherwise).
Non-Operating Humidity Range	Maximum relative humidity 90% for temperatures up to 65 °C (noncondensing).
Operating Altitude	4572 meters (15,000 ft)
Non-Operating Altitude	15,240 meters (50,000 ft)
EMC	Meets the conducted and radiated interference and immunity requirements of IEC/EN 61326-1. Meets radiated emission requirements of CISPR Pub 11/1997 Group 1 Class A.
Indoor/Outdoor Use	Indoor Use (unless specified otherwise)  This product is designed for use in INSTALLATION CATEGORY II and POLLUTION DEGREE 2, per IEC 61010-1 Second Edition and 664 respectively.

### Power Requirements:

Frequency	50 to 60 Hz
Voltage	100/115/230/240VAC
Power	40 Watts

### Weights and Dimensions:

Net Weight	9.1 kg (20 lb)
Dimensions	Height: 9 cm ( 3.54 in) Width: 42.5 cm ( 16.7 in) Depth: 50 cm ( 19.7 in)

## Video Feedthrough

Video leakage refers to the spurious signals present at the RF ports of the switch when it is switched without an RF signal present. These signals arise from the waveforms generated by the switch driver and, in particular, from the leading edge voltage spike required for high speed switching of PIN diodes. When measured into a 50  $\Omega$  system, the magnitude of the video leakage can be as much as several volts. The frequency content is concentrated in the band below 250 MHz, although measurable levels can be observed as high as several GHz. The magnitude of the video leakage can be reduced significantly by adding a high pass filter in the RF path Pulse Out to Filter In. The picture below shows the leading and trailing edges of video feedthrough.

**Figure 1-1** Video Filter

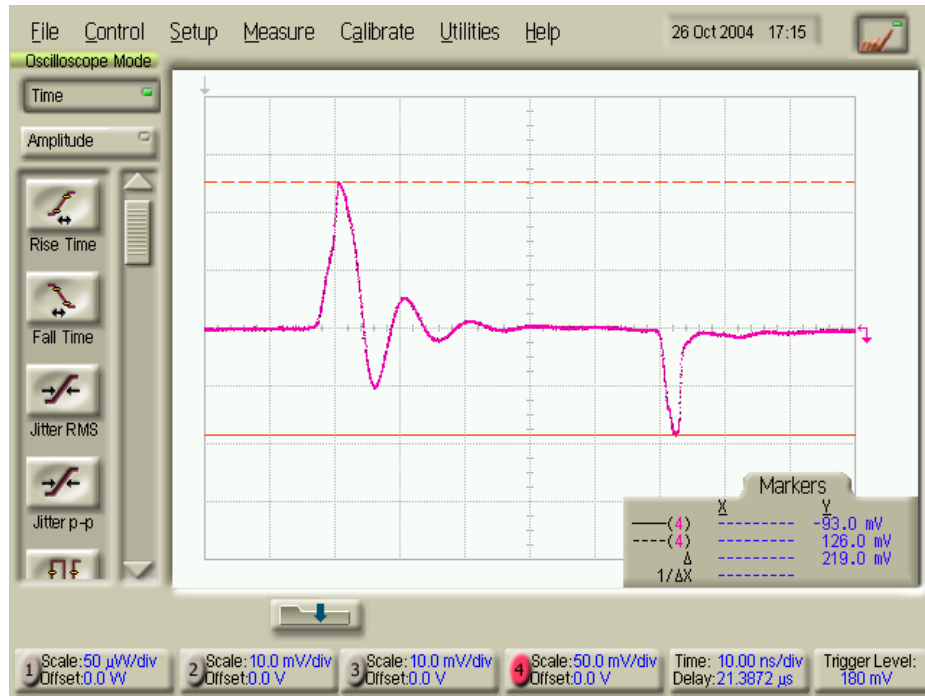

---

## Electrical Preparations

1. Ensure that the “[Electrical Requirements](#)” on page 2 are met.
2. Verify that the power cable is not damaged and that the power source outlet provides a protective earth ground contact. Note that [Figure 1-2](#) depicts only one type of power source outlet. Refer to [Figure 1-3](#) to see the different types of power cord plugs that can be used with your test set.

Cables are available in different lengths. For descriptions and part numbers of cables other than those described in [Figure 1-3](#), Refer to “[Contacting Agilent](#)” on page 71.

3. If this product is to be powered by autotransformer, make sure the common terminal is connected to the neutral (grounded) side of the ac power supply.

**Figure 1-2** Protective Earth Ground

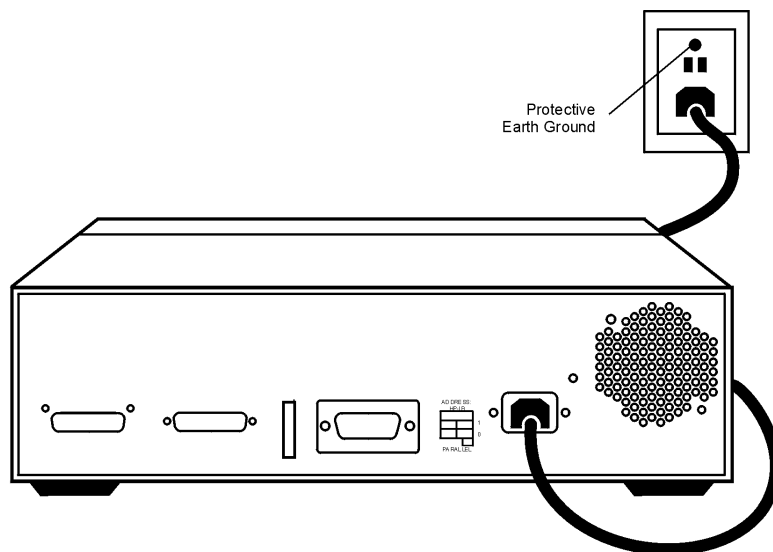



---

**WARNING**

**This is a Safety Class I product (provided with a protective earthing ground incorporated in the power cord). The mains plug shall only be inserted into a socket outlet provided with a protective earth contact. Any interruption of the protective conductor, inside or outside the instrument, is likely to make the instrument dangerous. Intentional interruption of the protective conductor is prohibited.**

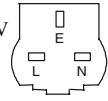
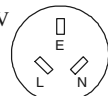
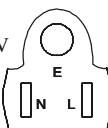
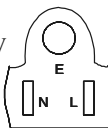
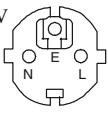
**Figure 1-3 Power Cables**

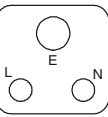
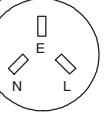
Plug Type <sup>a</sup>	Cable Part Number	Plug <sup>b</sup> Description	Length cm (in.)	Cable Color	For Use in Country
250V 	8120-8705	Straight BS 1363A	229 (90)	Mint Gray	Option 900 United Kingdom, Hong Kong, Cyprus, Nigeria, Singapore, Zimbabwe
	8120-8709	90°	229 (90)	Mint Gray	
250V 	8120-1369	Straight AS 3112	210 (79)	Gray	Option 901 Argentina, Australia, New Zealand, Mainland China
	8120-0696	90°	200 (78)	Gray	
125V 	8120-1378	Straight NEMA 5-15P	203 (80)	Jade Gray	Option 903 United States, Canada, Brazil, Colombia, Mexico, Philippines, Saudi Arabia, Taiwan
	8120-1521	90°	203 (80)	Jade Gray	
125V 	8120-4753	Straight NEMA 5-15P	229 (90)	Gray	Option 918 Japan
	8120-4754	90°	229 (90)	Gray	
250V 	8120-1689	Straight CEE 7/VII	200 (78)	Mint Gray	Option 902 Continental Europe, Central African Republic, United Arab Republic
	8120-1692	90°	200 (78)	Mint Gray	
230V 	8120-2104	Straight SEV Type 12	200 (78)	Gray	Option 906 Switzerland
	8120-2296	90°	200 (78)	Gray	
220V 	8120-2956	Straight SR 107-2-D	200 (78)	Gray	Option 912 Denmark
	8120-2957	90°	200 (78)	Gray	
250V 	8120-4211	Straight IEC 83-B1	200 (78)	Mint Gray	Option 917 South Africa, India
	8120-4600	90°	200 (78)	Mint Gray	
250V 	8120-5182	Straight SI 32	200 (78)	Jade Gray	Option 919 Israel
	8120-5181	90°	200 (78)	Jade Gray	

a. E = earth ground, L = line, and N = neutral.

b. Plug identifier numbers describe the plug only. The Agilent Technologies part number is for the complete cable assembly.



---

## Environmental Preparations

1. Ensure that the “[Electrical Requirements](#)” on page 2 are met.
2. If you are installing the test set into a cabinet, ensure there are at least two inches of clearance around the sides and back of the test set and the system cabinet. See [Figure 1-4](#). The convection into and out of the test set must not be restricted. The ambient temperature (outside the cabinet) must be less than the maximum operating temperature of the test set by 4 °C for every 100 watts dissipated in the cabinet.

**Figure 1-4** Ventilation Clearance Requirements

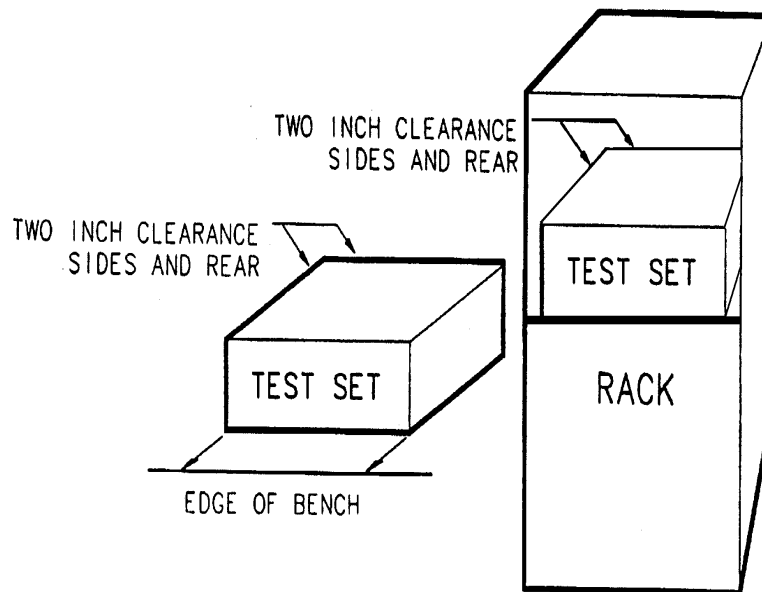

---

**CAUTION**

If the total power dissipated in the cabinet is greater than 800 watts, forced convection must be used.

---

---

## Electrostatic Discharge Protection

Protection against electrostatic discharge (ESD) is essential while removing or connecting cables or assemblies within the network analyzer.

Static electricity can build up on your body and can easily damage sensitive internal circuit elements when discharged. Static discharges too small to be felt can cause permanent damage. To prevent damage to the instrument:

- *always* wear a grounded wrist strap having a 1 M $\Omega$  resistor in series with it when handling components and assemblies.
- *always* use a grounded, conductive table mat while working on the instrument.
- *always* wear a heel strap when working in an area with a conductive floor. If you are uncertain about the conductivity of your floor, wear a heel strap.

Figure 1-5 shows a typical ESD protection setup using a grounded mat and wrist strap.

**Figure 1-5** ESD Protection Setup

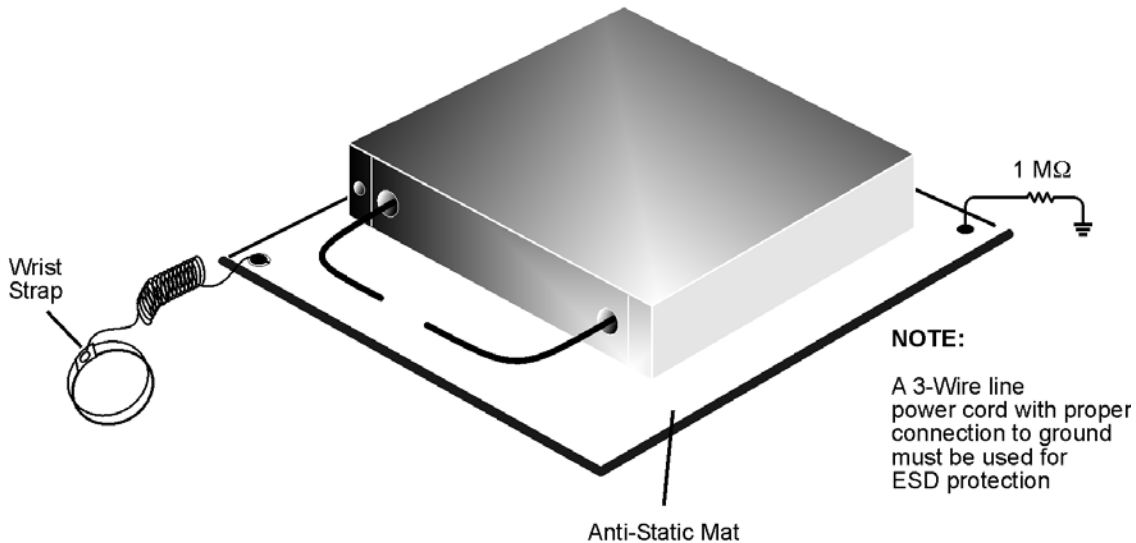

esd\_setup

---

## Test Set Familiarization

This section familiarizes the user with various front and rear panel features of the test set.

### Front Panel

**Figure 1-6 Front Panel Features**

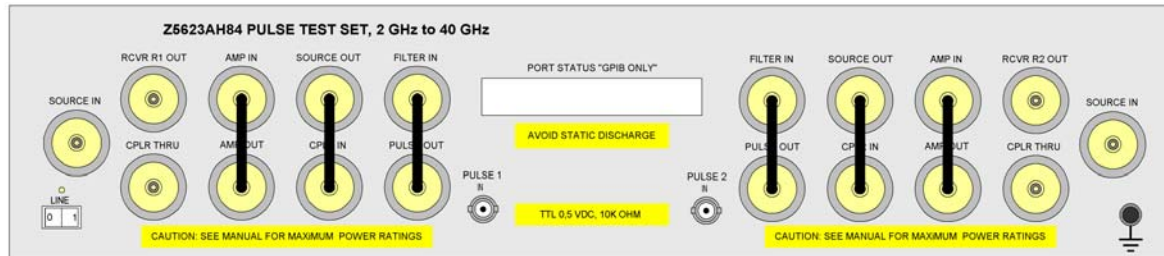

Z5623AH84\_SC  
Rev\_1

### Power On Switch

The Power On switch turns the AC power to the test set on and off. The switch is located at the bottom left corner of the front panel.

The switch disconnects the mains circuits from the mains supply after the EMC filters and before other parts of the instrument.

### Power LED

The power LED is illuminated when the power switch is in the on (1) position.

### RF Connectors

All of the RF connectors are 50  $\Omega$  2.4 mm connectors.

### Pulse Connector

The pulse input connector is a 50  $\Omega$  BNC female connectors.

## Rear Panel

Figure 1-7 Rear Panel Features



### Line Module

The line module contains the power cable receptacle and the line fuse.

### Power Cables

The line power cable is supplied in one of several configurations, depending on the destination of the original shipment.

Each instrument is equipped with a three-wire power cable. When connected to an appropriate ac power receptacle, this cable grounds the instrument chassis. The type of power cable shipped with each instrument depends on the country of destination. See [Figure 1-3 on page 8](#) for the part numbers of these power cables.

---

#### WARNING

**This is a Safety Class I product (provided with a protective earthing ground incorporated in the power cord). The mains plug shall only be inserted in a socket outlet provided with a protective earth contact. Any interruption of the protective conductor, inside or outside the instrument, is likely to make the instrument dangerous. Intentional interruption is prohibited.**

---

### The Line Fuse

The line fuse (F 3 A/250 V, 2110-0780) and a spare reside within the line module. [Figure 1-8](#) illustrates where the fuses are and how to access them.

**Figure 1-8** Location of Line Fuses

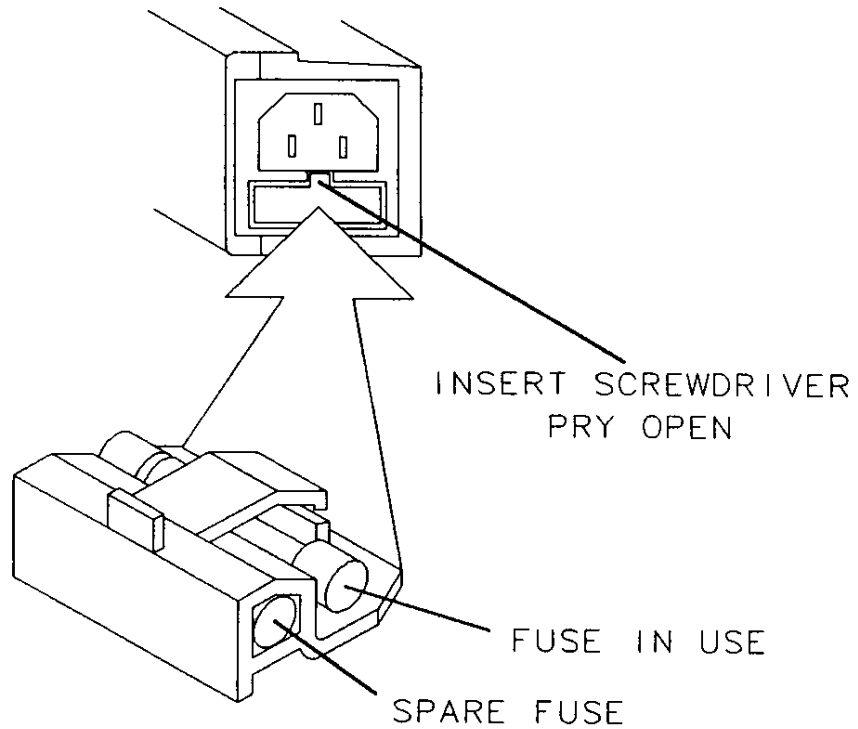

## Operation Overview

The [Agilent Technologies Z5623A Option H84](#) Dual Directional Pulse Test Set can be configured differently for many applications. Included in this document are four typical configurations:

- [Figure 1-10, “Shipped Configuration.”](#)
- [Figure 1-11, “System Setup Configuration.”](#)
- [Figure 1-12, “High Power Pulse Forward Direction.”](#)
- [Figure 1-13, “High Power Pulse Dual Direction.”](#)
- [Figure 1-14, “Pulse Dual Direction.”](#)

---

**NOTE** The internal firmware of the PNA has not been modified for this test set option. The power levels indicated on the Agilent E8363B and E8364B may differ depending on the user configuration that is chosen.

---

Refer to the configuration diagrams for external component connections and/or operating constraints when utilizing the high power capability of the Agilent Z5623AH84 Dual Directional Pulse Test Set. External components are not supplied with this option other than those in the [Table 1-1 on page 4](#).

When using the Agilent E8363B and E8364B Series Network Analyzer with Z5623AH84 Dual Directional Pulse Test Set in the bypass or the high power configuration, the PNA Frequency Offset mode (Option 080) and External R1 (Option 081) must be activated. This will ensure phase lock and allow R1 and R2 to receive the new reference power levels from the amplifiers. Refer to [Table 1-2 on page 15](#).

---

**CAUTION** The Z5623AH84 is equipped with reference channel attenuators. These attenuators reduce the RF power to the PNA R1 and R2 receiver ports. The test set attenuators can be set from 0 to 60 dB in 10 dB steps. The recommended power levels to the PNA R1 and R2 receiver ports is –15 dBm. Refer to your PNA specifications to optimize power levels to the receiver ports.

The PNA Option 016, Receiver Step Attenuators, reduces the power to the A and B receivers. The A and B maximum attenuator setting is 35 dB. Power measurements to Test Ports 1 and 2 above +35 dBm will require additional attenuation. Add the appropriate amount of attenuation that will keep the coupler arm output power below –15 dBm. Refer to [Table 1-2](#).

---

**CAUTION** Hot Switching is not allowed with the Z5623AH84 when making high power measurements or damage to the switch will occur. Hot Switching is the condition when the internal switch or switches are set to a position for making high power measurements, and then set to another position without reducing the power. The maximum power that the switches are allowed to switch states is +20 dBm.

---

---

**CAUTION** Prior to powering-up the booster amplifier, it is highly recommended that the user verify the RF power levels seen by the various elements of the test setup. At high power levels a mistake could permanently damage the instrument. Refer to [Table 1-2](#).

---

**Table 1-2 Power Levels**

Test Setup	Power Level
<b>Maximum Z5623AH84 RF Power Levels to Access Ports:</b>	
SOURCE IN	+20 dbm
RCVR R1 OUT, RCVR R2 OUT	+20 dBm
CPLR THRU, CPLR IN, AMP OUT	+43 dBm @ 10 MHz to 40 GHz
CPLR THRU, CPLR IN, AMP OUT	+40 dBm @ 40 GHz to 50 GHz
AMP IN, SOURCE OUT	+30 dBm
FILTER IN	+30 dBm (Dependent on Filter)
PULSE OUT	+20 dbm (Dependent on Filter)
AMP 1 IN TERM, AMP 2 IN TERM	+30 dBm
AMP 1 OUT TERM, AMP 2 OUT TERM	+30 dbm
<b>Maximum PNA RF Power Levels to Access and Test Ports:</b>	
Max Recommended RF Level at A/B/R1/R2 Receivers	-15 dbm
Damage Level at A/B/R1/R2 Receivers	+15 dbm
Max Recommended RF Level at Port 1, 2 Source	+0 dBm
Damage Level to Port 1, 2 SOURCE OUT	+20 dBm
Max Level to Port 1, 2 Test Ports	+20 dBm

---

**NOTE** Refer to your PNA specifications to optimize the power levels in the receivers.

---

**NOTE** We recommend that you do NOT operate components near damage or maximum levels. The power levels should be kept at less than 3 dB, preferably 6 dB, below damage and maximum levels. Damage and Maximum levels are not necessarily the optimum level.

---

Figure 1-9 Maximum Power Levels

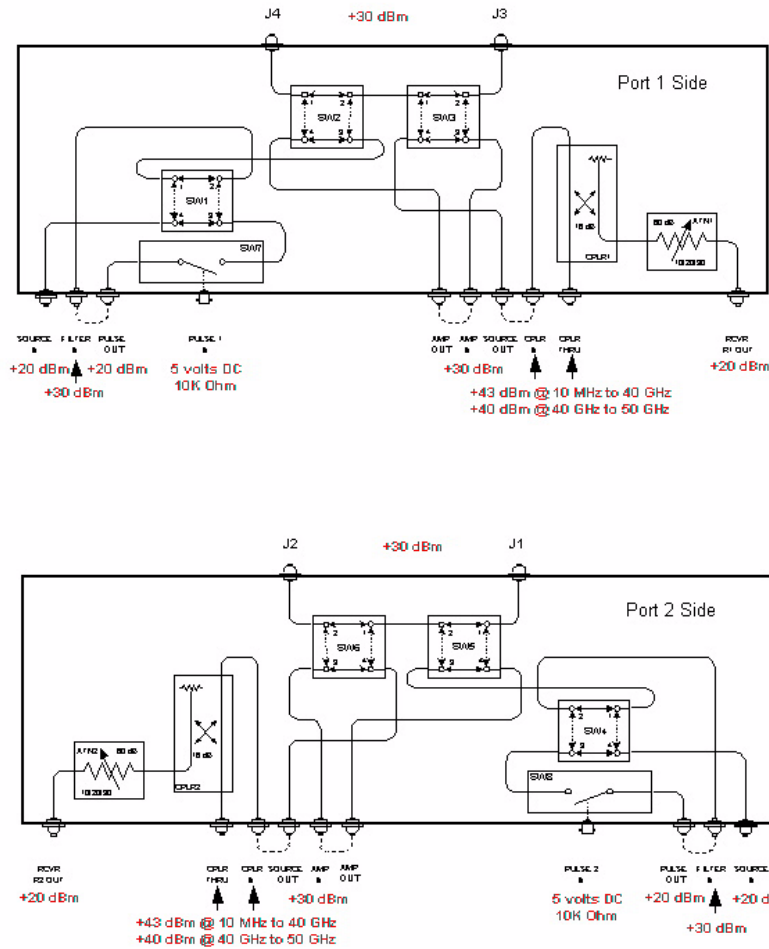
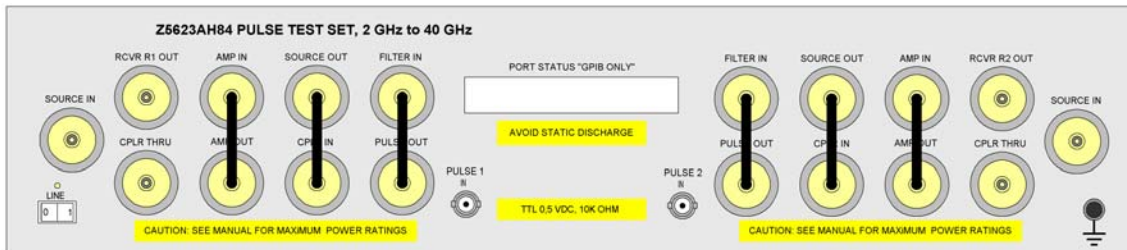

Figure 1-10 Shipped Configuration



Z5623AH84\_SC  
Rev\_1



## System Setup

Figure 1-11 on page 18 shows the setup configuration of the [Agilent Technologies Z5623A Option H84](#) Dual Directional Pulse Test Set and how it should be configured with the PNA and the Pulse Pattern Generators.

1. Connect the following RF Cables:
  - Connect RF Cable (5063-9803) from the Test Set RCVR R1 or R2 to the PNA RCVR R1 or R2 IN.
  - Connect RF Cable (5063-9804) from the Test Set SOURCE IN to the PNA SOURCE OUT (Ports 1 & 2).
  - Connect RF Cable (5063-9805) from the Test Set CPLR THUR to the PNA CPLR THUR (Ports 1 & 2).

---

**NOTE** The test set rear panel connections are not shown in [Figure 1-11](#).

2. Connect the external 50  $\Omega$  loads (0955-0608) on Test Set RF Ports to J1, J2, J3, and J4.
3. Connect the test set's 37-Pin D-SUB jumpers (Z5623-60202) to the rear panel Port 1 and Port 2 connectors for GPIB and parallel control.
4. Connect the GPIB cable from the PNA, Test Set and Pulse Pattern Generators. (These cables are not supplied).
5. Connect a BNC cable for the 10 MHz Reference between the PNA and the Pulse Pattern Generators. (These cables are not supplied).
6. Connect the four BNC cables from each Pulse Pattern Generators Output 1 and 2 to the PNA rear panel IF Inputs. (These cables are not supplied).
7. Connect a BNC cable from the test sets PULSE 1 IN and 2 IN to the Pulse Pattern Generator. (These cables are not supplied).

Figure 1-11 System Setup Configuration

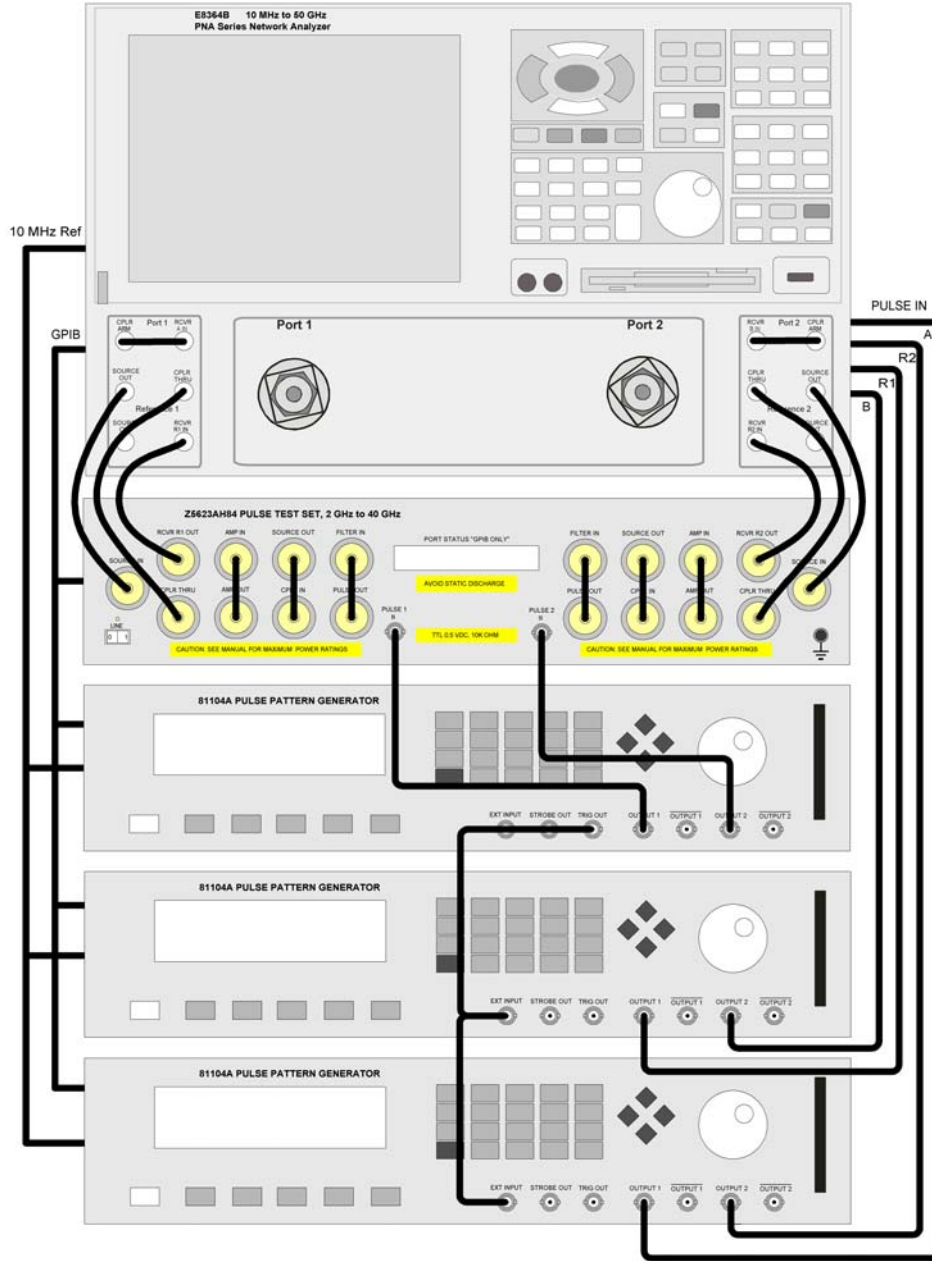

## Z5623A Option H84 System Setup

In the following diagrams a high power isolator or attenuator *must* be inserted at the front panel CPLR IN and SOURCE OUT to protect the internal test set modulator PIN-switch and the PNA solid state transfer switch (30 dB isolation recommended), or if reverse isolation of the amplifier is less than 30 dB. Maximum power into the modulator PIN-switch is 20 dBm for both forward and reverse directions. Optimum power level to all receivers is  $-15$  dBm.

- Insert attenuators (A, B, R1 and R2 ports) to reduce power to the receivers accordingly.
- Set the initial instrument state to  $-65$  dBm test port power level to reduce the risk of damage when powering on the unit.
- The recommended sweep mode is [STEP].
- Frequency Offset mode must be **On** and the R1 reference channel should be set to **External**.

**Figure 1-12 High Power Pulse Forward Direction**

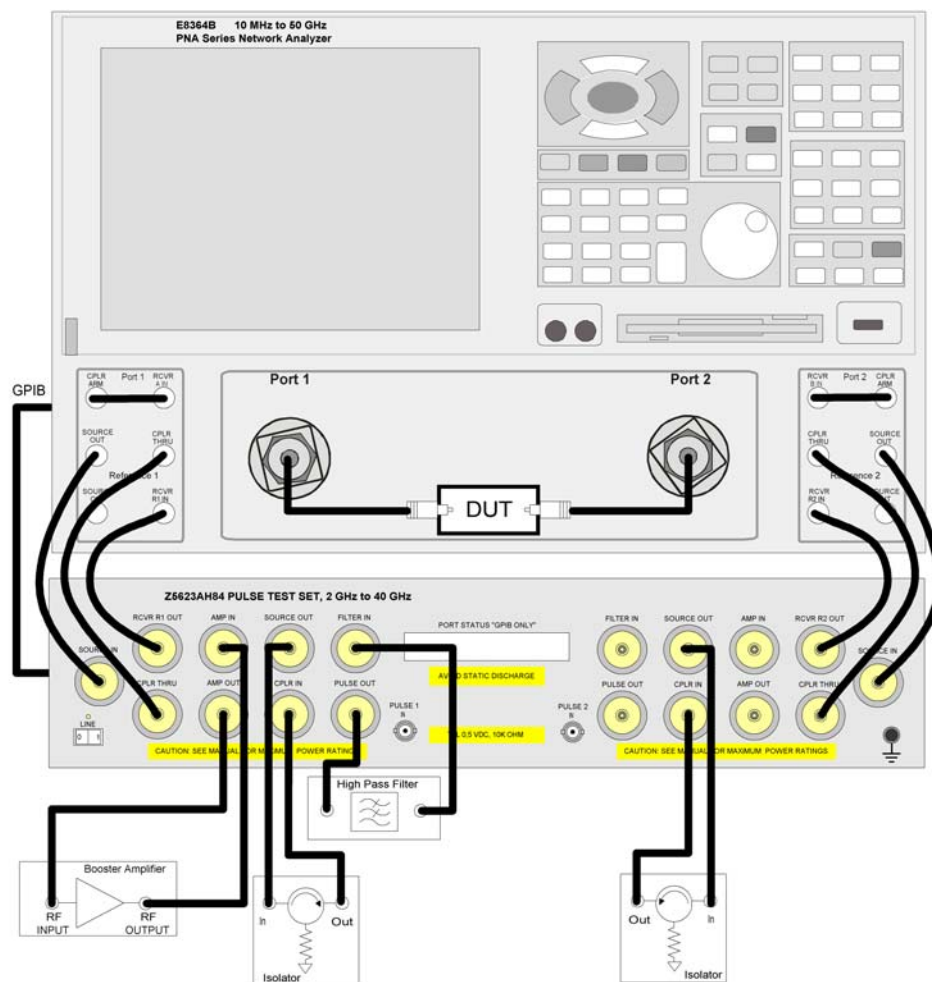

Z5623AH84\_HPFDF  
Rev 1

Figure 1-13 High Power Pulse Dual Direction

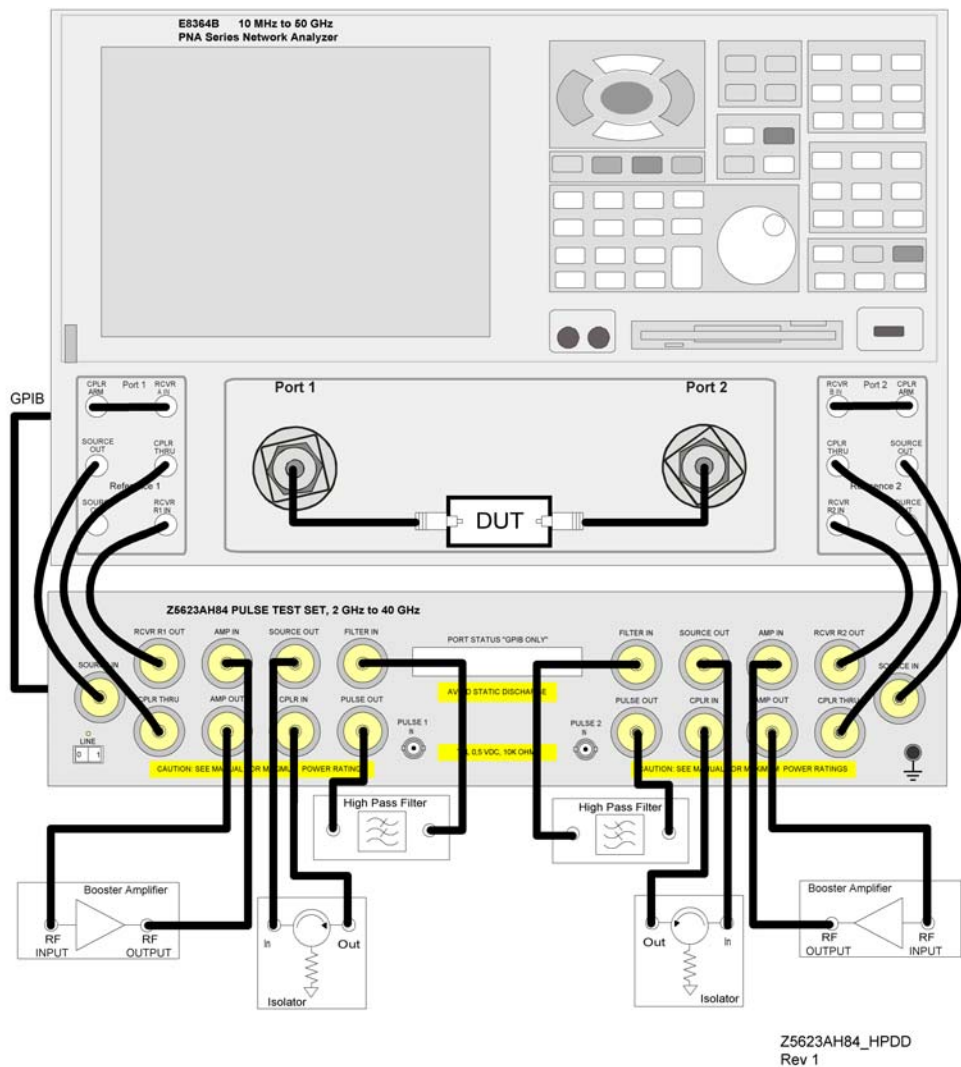
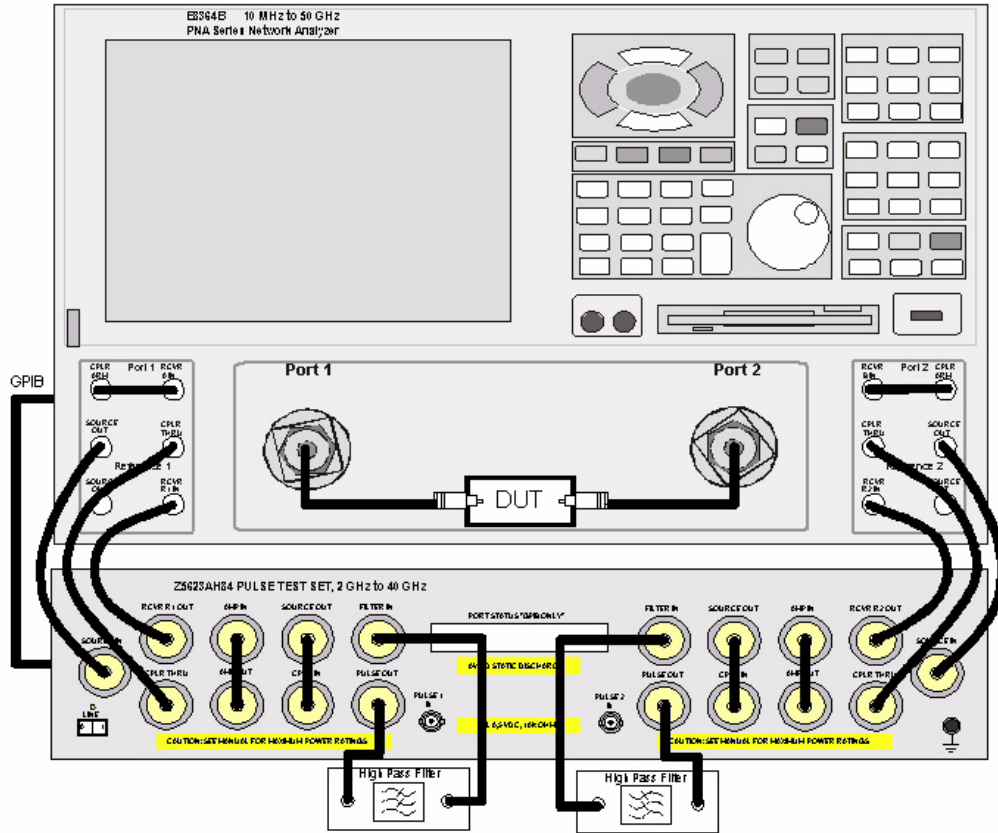

Figure 1-14 Pulse Dual Direction



Z5623AH84\_PDD  
Rev 1

## Controlling the Test Set

The [Agilent Technologies Z5623A Option H84](#) is considered a “slave” instrument. A Controller must be used to control the test set. There are four ways to control the test set:

- The PNA can be used as the controller to talk to the test set over the GPIB.
- A Controller can directly talk to the test set over the GPIB.
- The Parallel port can be used to set the test set.
- Direct control access to the internal switches and attenuators via open collector lines to ground the input lines.

## Commands

As mentioned before, the test set can be controlled in four ways. The first two involve the use of a separate computer. The third way uses parallel port manually. The fourth control method uses direct access from two rear panel 37 pin D-Sub connectors.

---

**NOTE** The 37 pin D-Sub jumpers (Z5623-60202) must be attached to the test sets Port 1 and 2 rear panel direct access connectors for the GPIB and parallel port commands to work. These connectors are not connected to the test set when they are shipped.

---

## Typeface Key Conventions

The following key conventions are used throughout this document.

- **[HARDKEYS]** are labeled front panel keys.
- **SOFTKEYS** are unlabeled key whose function is indicated on the instrument display.

## PNA Control

Write the GPIB commands from the PNA directly to the [Agilent Technologies Z5623A Option H84](#) test set GPIB port located on the rear panel. The following example assumes that the address of the test set is set to 12. Be sure to use an ending semi-colon.

The PNA must first be setup as the Controller.

1. Select **System > Configure > SICL/GPIB > System Controller**. Under System, select Configure then SICL/GPIB. Once the SICL/GPIB appears in the GPIB section click on System Controller, press OK and close the window.

**Figure 1-15** SICL/GPIB

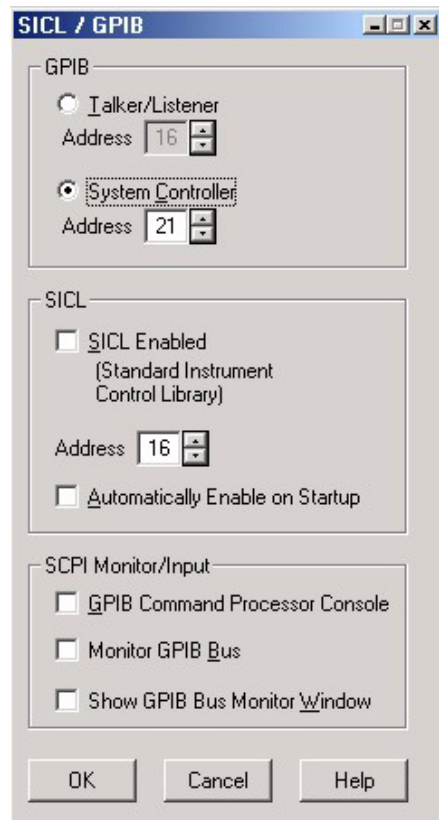

2. Launch the **Measurement & Automation** icon located on the PNA desk top.
3. Expand **Devices and Interfaces**.
4. Right click on **GPIB0 (AT-GPIB/TNT)** and select **Interactive control**. When the new window appears at the prompt type the following:  
: ibdev (This command sets up the PNA GPIB to talk to the [Agilent Technologies Z5623A Option H84](#) test set)

```
enter board index: 0  
enter primary address: 12
```

## Z5623A Option H84 Controlling the Test Set

```
enter secondary address: 0
enter timeout: 0
enter 'EOI on last byte' flag: 0
enter end-of-string mode/byte: 1
ibwrt:"command$;" (Command$ is the string the user would get from the table)
```

**Figure 1-16 Interactive Control**

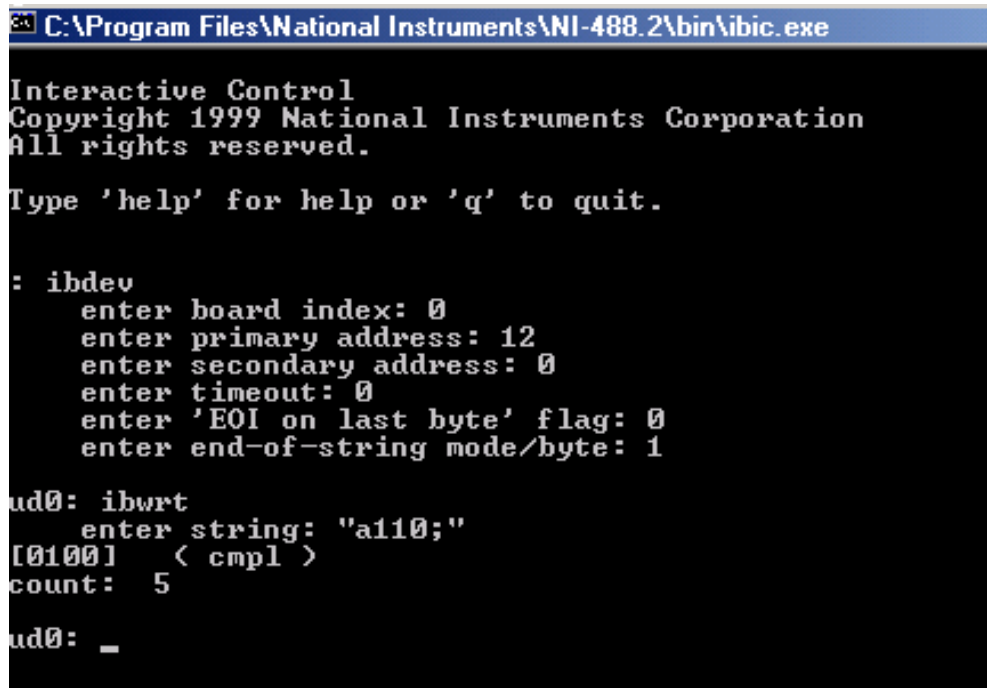

```
C:\Program Files\National Instruments\NI-488.2\bin\ibic.exe

Interactive Control
Copyright 1999 National Instruments Corporation
All rights reserved.

Type 'help' for help or 'q' to quit.

: ibdev
  enter board index: 0
  enter primary address: 12
  enter secondary address: 0
  enter timeout: 0
  enter 'EOI on last byte' flag: 0
  enter end-of-string mode/byte: 1

ud0: ibwrt
  enter string: "a110;"
[0100] (< cmpl )
count: 5

ud0: _
```

## Addressing Directly

Write GPIB commands from the controller to write commands directly to the [Agilent Technologies Z5623A Option H84](#) test set GPIB port located on the rear panel. The following RMB example assumes that the address of the test set is set to 712.

### RMB

```
OUTPUT 712;"command$;"
```

To query and read from the [Agilent Technologies Z5623A Option H84](#) test set, the user needs to send two commands. The first queries the test set for an individual switch count, and the second reads the data as a string. Be sure to use an ending semi-colon. See your manual regarding details for switching the identifier.

```
OUTPUT 712;"sw10?;"!Query test set for switch 10
```

```
ENTER 712;"Count$;" !Read switch 10 Count
```



Z5623A Option H84  
Controlling the Test Set

To query and read from the [Agilent Technologies Z5623A Option H84](#) test set for identification, the user needs to send two commands. The first queries the test set for an ID, and the second reads the data in as a string. See your manual for details for “ID Identifier read.”

```
OUTPUT 712;"idn?;"!Query test set for ID
ENTER 712;"Name$;"!Read test set ID
```

**VEE**

When using VEE insure the Direct I/O is set as follows. This is also the default Direct I/O settings.

**Figure 1-17 Direct I\O**

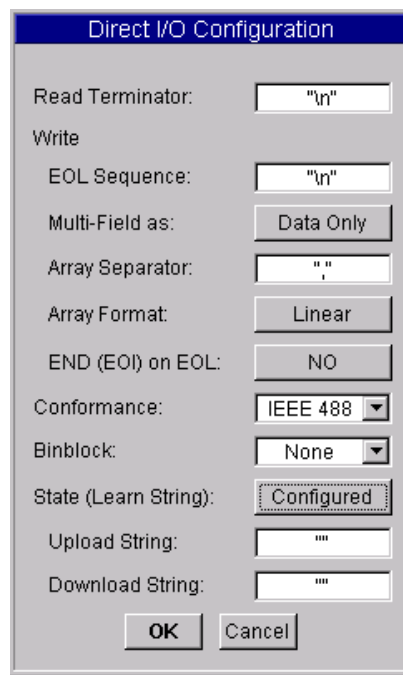

To send commands to the test set configure the I/O Transaction as follows:

**Figure 1-18 I\O Transaction**

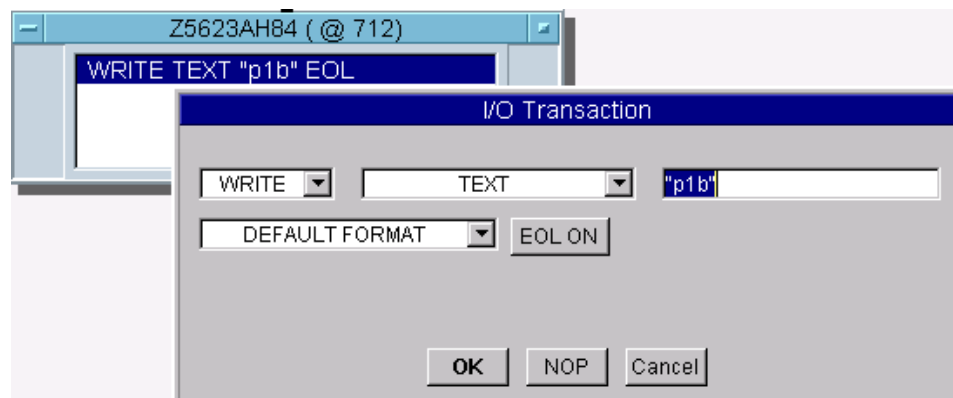

Querying and read from the test set is the same for both switch count and box ID.

**Figure 1-19 Query/Read**

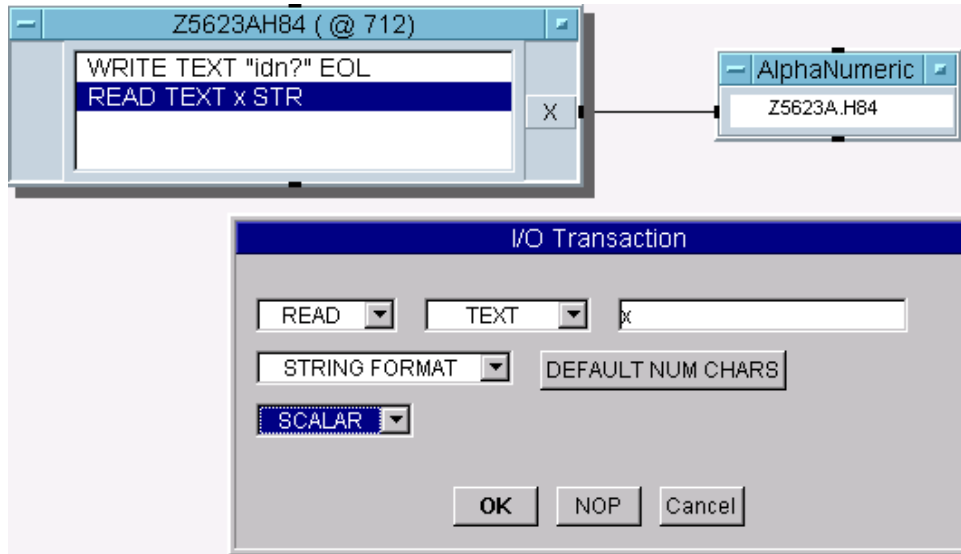

### Quick Basic

If you are using Quick Basic or Visual Basic, be sure to disable EOI and EOL before sending commands to the test set. Including the semicolon in program commands will not ensure that these commands are disabled as would be the case in HP Basic/RMB. When using the 82335 GPIB Interface and Visual Basic, use the following commands to disable EOI and EOL, send the necessary data to the test set, and re-enable EOI and EOL.

---

**NOTE** Be sure to re-enable EOI and EOL before sending data to another instrument.

---

### Write Commands

```
GpibEoi(hGpib;7,0) 'disable EOI
GpibEol(hGpib;7, "",0) 'disable EOL
GpibOutputs(hGpib;712,info$,length%) 'send command to test set.
GpibEol(hGpib;7,chr$(13)+chr$(10),2) 're-enable EOL and set to
chr$(13)+chr$(10)
GpibEoi(hGpib;7,1,) 're-enable EOI where hGpib specifies the handle
returned by GpibOpen
```

## Read Commands

```
info$ = "sw10?" 'query sw10 for switch count
length% = len(info$) 'length of command
max.len% =10 'max length data form idn? or swxx? function
infi$ = space$(max.len%)
GpibEoi(hGpib;7,0) 'disable EOI
GpibEol(hGpib;7, "",0) 'disable EOL
GpibOutputs(hGpib%,712,info$,length%) 'send query command to tests
set.
GpibEnters(hGpib%,712,infi$,max.len%) 'get data from tests set.
GpibEol(hGpib;7,chr$(13)+chr$(10),2) 're-enable EOL
GpibEoi(hGpib;7,1,) 're-enable EOI
```

## National Instruments VISA

If you are using National Instruments VISA, be sure to set the variables as follows:

`VI_ATTR_SEND_END_ENVI = FALSE` ` This specifies whether to assert END during the transfer of the last byte of the buffer.

`VI_ATTR_TERMCHAR = 0x0A` ` This is the termination character. When the termination character is read and `VI_ATTR_TERMCHAR_EN` is enabled during a read operation, the read operation terminates.

`VI_ATTR_TERMCHAR_EN = VI_TRUE` ` This is a flag that determines whether the read operation should terminate when a termination character is received.

`VI_ATTR_SUPPRESS_END_EN = VI_FALSE` ` This specifies whether to suppress the END bit termination. If this attribute is set to `VI_TRUE`, than the END bit does not terminate read operations. If this attribute is set to `VI_FALSE`, than the END bit terminates read operations.

## Write Commands:

Append all commands with `\n`. For example; `*rst\n`

## Read Commands:

The test set returns data terminated by `\r\n`. For example the query `sw10?\n` returns `00000010\r\n`.

## Parallel Port

The third way is used by the service center or during production to verify the port path connections. This uses the parallel port on the rear panel of the [Agilent Technologies Z5623A Option H84](#). This method uses an 8722ES Network Analyzers Parallel port to control the test set. The following example assumes that the address of the network analyzer is set to 16. Be sure to use an ending semi-colon.

```
OUTPUT 716;"PARALGPIO"; (Sets the parallel port for GPIO function).
OUTPUT 716;"PARAOUT[D]; (Programs all GPIO output bits (0 to 256) at once).
```

**Table 1-3 GPIB and Parallel Commands**

GPIB	Description	LCD Display	Parallel	Decimal
A100	RCVR R1 Attenuator 0 dB	A00	00000000	0
A110	RCVR R1 Attenuator 10 dB	A10	00000001	1
A120	RCVR R1 Attenuator 20 dB	A20	00000010	2
A130	RCVR R1 Attenuator 30 dB	A30	00000011	3
A140	RCVR R1 Attenuator 40 dB	A40	00000100	4
A150	RCVR R1 Attenuator 50 dB	A50	00000101	5
A160	RCVR R1 Attenuator 60 dB	A60	00000110	6
A200	RCVR R2 Attenuator 0 dB	A00	00000111	7
A210	RCVR R2 Attenuator 10 dB	A10	00001000	8
A220	RCVR R2 Attenuator 20 dB	A20	00001001	9
A230	RCVR R2 Attenuator 30 dB	A30	00001010	10
A240	RCVR R2 Attenuator 40 dB	A40	00001011	11
A250	RCVR R2 Attenuator 50 dB	A50	00001101	12
A260	RCVR R2 Attenuator 60 dB	A60	00001110	13
P1B	Port 1 Bypass Mode	P1 Bypass Axx	00001110	14
P1HPB	Port 1 High Power Mode	P1 HP Bypass Axx	00001111	15
P1HPP	Port 1 High Power Pulse Mode	P1 HP Pulse Axx	00010000	16
P1P	Port 1 Pulse Mode	P1 Pulse Axx	00010001	17
P2B	Port 2 Bypass Mode	P2 Bypass Axx	00010010	18
P2HPB	Port 2 High Power Mode	P2 HP Bypass Axx	00010011	19
P2HPP	Port 2 High Power Pulse Mode	P2 HP Pulse Axx	00010100	20
P2P	Port 2 Pulse Mode	P2 Pulse Axx	00010101	21
*RST	Reset (Port 1 and 2 Bypass Mode)	P1 Bypass A00 P2 Bypass A00	00010110	22
<b>Display</b>		<b>Description (GPIB)</b>		
IDN?	Z5623A H84	Read Test Set ID		
	ERR: invalid command	Non GPIB or Parallel Command Sent		

## Direct Control

The fourth method to control the test set uses the Port 1 and Port 2, 37 pin D-Sub connectors located on the rear panel. Jumper connectors (Z5623-60202) must not be attached to allow the user to control the internal switches and attenuators. Refer to [Table 1-5 on page 33](#) which shows the pinout and function for Port 1 and 2.

---

**NOTE** LCD indicator is only valid when the test set is used in control methods; PNA, Controller, and Parallel. Direct control does not change the LCD indicator when either the switches or attenuators are repositioned.

---

## Controlling the Switches

Control of the internal switches directly, is provided from the 37 pin D-Sub connector and can be done in two ways.

- TTL
- Open Collector

The TTL input allows the user independent switch position control by either a low (0) or high (1). The TTL voltage is 0 or 5 volts. The [Figure 1-20 on page 30](#). The 37 Pin D-Sub connector shows the rear panel input/output configuration for Port 1. Port 2 is identical to Port 1 but where SW1 is replace by SW4, SW2 is replace by SW5, SW3 is replace by SW6 on the RF block diagram. Pins 5, 12, 22 are the TTL input pins. Pin 5 controls SW1 or SW4, pin 12 controls SW3 or SW6, and pin 22 controls SW2 or SW5.

The Open Collector inputs allows the user to control a switch position by grounding either the A (AD) or B (BD) drive input lines for each switch. Only one of these two input lines can be grounded at any given moment. Recommended is break before making when the input line position changes. [Figure 1-20](#). The 37 Pin D-Sub connector shows the rear panel input/output configuration for port 1. Port 2 is identical to port 1 but where SW1 is replace by SW4, SW2 is replace by SW5, SW3 is replace by SW6 on the RF block diagram. Pins (1,2), (8,9), and (25,26) are the A and B drives input pins. Pins 1, 2 control SW1 or SW4, pins 8, 9 control SW3 or SW6, and pins 25, 26 control SW2 or SW5.

## Switch Indicators

The internal switch positions can be read only when used in the Direct Control method. A switch position can be read by either a low (0) or high (1) on the A (AI) or B (BI) indicator lines. The voltage is either 0 or 5 volts depending on the switch position. Low (0) indicates disabled, and high (1) indicates enabled. [Figure 1-20](#) shows the rear panel input/output configuration for port 1. Port 2 is identical to port 1 but where SW1 is replace by SW4, SW2 is replace by SW5, SW3 is replace by SW6 on the RF block diagram. Pins (3,4), (10,11), and (23,24) are the A and B indicator output pins. Pins 3, 4 indicate SW1 or SW4 position, pins 10, 11 indicate SW3 or SW6 position, and pins 23, 24 indicate SW2 or SW5 position. [Figure 1-21 on page 30](#) shows how each switch is configured.

**Figure 1-20 37 Pin D-Sub Connector**

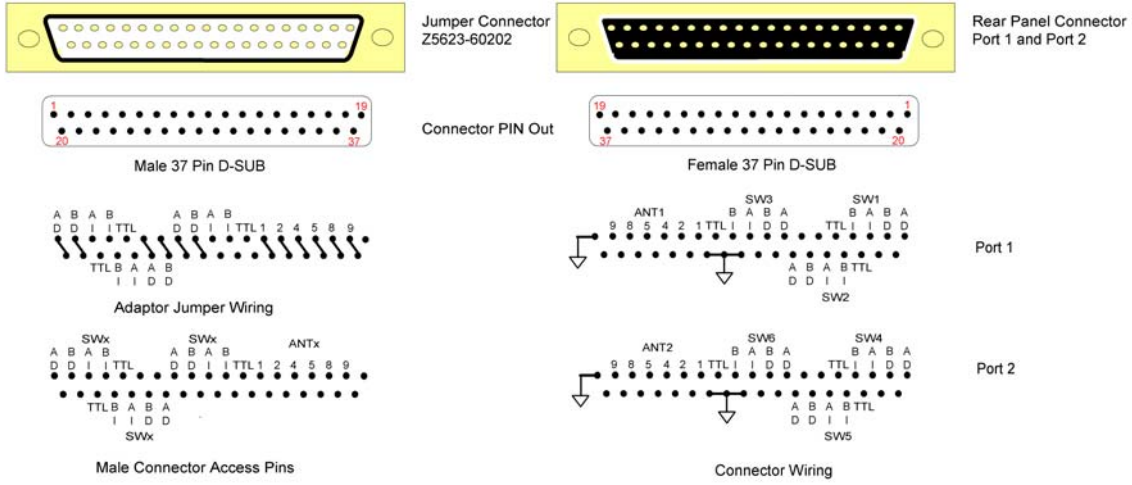

**Figure 1-21 Switch Connection**

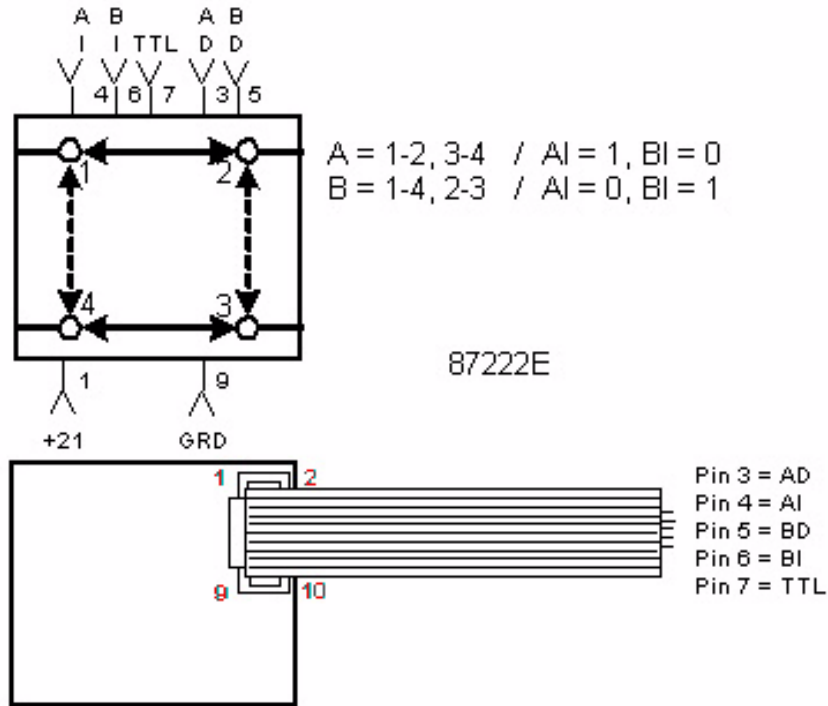

## Switch Indicator Function

The 87222E is set to the A or B Position. Refer to [Table 1-6 on page 34](#), Switch Indicator Voltages for Test Set Modes. When the switch is set to the A position the Indicator Common is connected, completing the A Indicator path. The 21 VDC connected to the Indicator Common is connected to ground by two resistors (30 kΩ and 10 kΩ). The Position A and B Indicators have independent 10 kΩ resistors to ground. The measured voltage from Position A Indicator to ground is approximately 5 Volts and the Position B Indicator will measure 0 Volts. When the switch is set to Position B, the Indicator common is connected. Measuring the voltage from Position B Indicator to ground will measure approximately 5 Volts and the A indicator will measure 0 Volts.

### Example 1 A Indicator Position Connected

- Resistance Indicator Common in a connected path = 40 kΩ
- Resistance between the Indicator Common and Position A when connected = 30 kΩ
- Resistance between Position A and ground = 10 kΩ
- Resistance between the Indicator Common and Position B when connected = OPEN
- Resistance between Position B and ground = 10 kΩ
- $I = V/R = 21 \text{ V}/40 \text{ k}\Omega = 0.525 \text{ mA}$
- Voltage drop across 30 kΩ resistor:  $V = I \times R = 0.525 \text{ mA} \times 30 \text{ k}\Omega = 15.75 \text{ Volts}$
- Voltage drop across 10 kΩ resistor:  $V = I \times R = 0.525 \text{ mA} \times 10 \text{ k}\Omega = \text{Position A indicator to ground} = 5.25 \text{ Volts}$

In that the Position B switch to the Indicator Common is open, only the 10 kΩ resistor ground is connected providing a pull down on the Position B Indicator pin, effectively grounding it.

**Figure 1-22** Switch Indicator Status

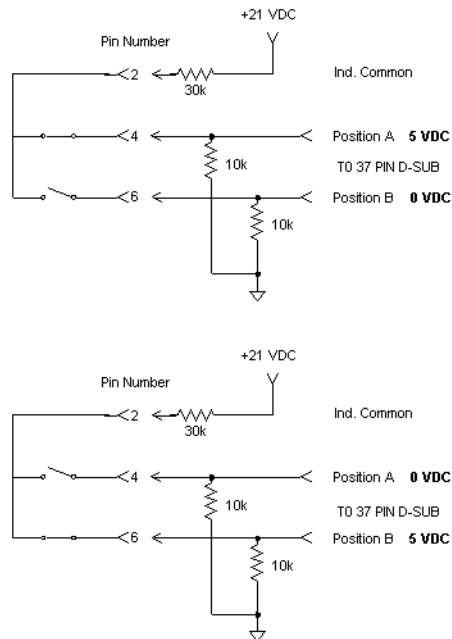

## Controlling the Attenuators

Controlling the attenuators are identical to the Switch Open Collector control method. [Figure 1-20 on page 30](#) shows the rear panel input/output configuration for Port 1. Port 2 is identical to port 1, but ANT1 is replaced by ANT2. Pins 13-18 control the attenuator. Like the switch open collector lines, brake before making the attenuator bypass or select setting changes.

**CAUTION** Always break-before-make a selection when using the Open Collector control inputs for the switches and attenuators. Failure to do so can damage the internal switches or attenuators.

**CAUTION** Make rear panel Direct Control connections while the test set is off. Ensure that all inputs are OFF before making any connection. Turn off the test set before removing the connector jumper. Failure to do so can damage the internal switches or attenuators.

**Table 1-4 Attenuator Connections**

Pin	Description
13	10 dB bypass
14	10 dB select
15	30 dB bypass
16	20 dB bypass
17	20 dB select
18	30 dB select

**Figure 1-23 Attenuator Connection**

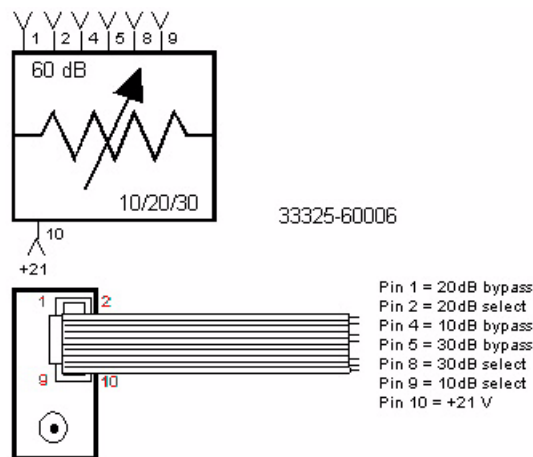



Z5623A Option H84  
Controlling the Test Set

**NOTE** Switches and attenuators supply voltage is supplied internally by the test set. The supply voltage is 21 Vdc.

**NOTE** LCD indicator is only valid when the test set is used in the following control methods; PNA, Controller, Parallel. Direct Control does not change the LCD indicator when the switches or attenuators are repositioned.

**Table 1-5 Rear Panel Connection for Port 1 and Port 2**

Pin #	Switch	Function	Port 1	Description	Switch Position	Pin Bias Switch Control
1	1&4	AD	SW1	Position A Drive	1 to 2; 3 to 4	1=gnd; 2=OPEN
2	1&4	BD	SW1	Position B Drive	1 to 4; 2 to 3	1=OPEN; 2=gnd
3	1&4	AI	SW1	Position A Indicator	A= 5 volts; B= 0 volts	
4	1&4	BI	SW1	Position A Indicator	A= 0 Volts; B= 0 volts	
5	1&4	TTL	SW1	TTL Drive	A=High; B=Low	A=5 volts; B=gnd
26	2&5	AD	SW2	Position A Drive	1 to 2; 3 to 4	1=gnd; 2=OPEN
25	2&5	BD	SW2	Position B Drive	1 to 4; 2 to 3	1=OPEN; 2=gnd
24	2&5	AI	SW2	Position A Indicator	A= 5 volts; B= 0 volts	
23	2&5	BI	SW2	Position B Indicator	A= 0 volts; B= 5 volts	
22	2&5	TTL	SW2	TTL Drive	A=High; B=Low	A=5 volts; B=gnd
8	3&6	AD	SW3	Position A Drive	1 to 2; 3 to 4	1=gnd; 2=OPEN
9	3&6	BD	SW3	Position B Drive	1 to 4; 2 to 3	1=OPEN; 2=gnd
10	3&6	AI	SW3	Position A Indicator	A= 5 volts; B= 0 volts	
11	3&6	BI	SW3	Position B Indicator	A= 0 volts; B= 5 volts	
12	3&6	TTL	SW3	TTL Drive	A=High; B=Low	A=5 volts; B=gnd
Pin #	Attenuator	Function	Port 1	Description	Attenuator Position	Pin Bias Atten Control
13	1&2	10 OUT	Atten1	10 dB Bypass	0	13=gnd; 14=OPEN
14	1&2	10 IN	Atten1	10 dB Select	10	13=OPEN; 14=gnd
15	1&2	30 OUT	Atten1	30 dB Bypass	0	15=gnd; 18=OPEN
16	1&2	20 OUT	Atten1	20 dB Bypass	0	16=gnd; 17=OPEN
17	1&2	20 IN	Atten1	20 dB Select	20	16=OPEN; 17=gnd
18	1&2	30 IN	Atten1	30 dB Select	30	15=OPEN; 18=gnd

**Table 1-6**      **Switch Indicator Voltages for Test Set Modes**

VDC	SW1		SW2		SW3		SW4		SW5		SW6	
	AI	BI	AI	BI	AI	BI	AI	BI	AI	BI	AI	BI
Bypass	0	5	0	5	0	5	0	5	0	5	0	5
HP Bypass	0	5	5	0	5	0	0	5	5	0	5	0
Pulse	5	0	0	5	0	5	5	0	0	5	0	5
HP Pulse	5	0	5	5	5	0	5	0	5	0	5	0

**NOTE**

Indicator position voltages are influenced by the user's interface. High impedance, sensor, or TTL input may be used to monitor the indicator position lines.

## Making High Power Measurements With Option H84

The [Agilent Technologies Z5623A Option H84](#) and PNA with Options 014, 016, 080, 081, and UNL or H85 can be configured to measure high power devices. This ability is useful if the required power for the device under test is greater than the analyzer can provide, or if the maximum output power from an amplifier under test exceeds safe input limits for a test set and analyzer. This section describes how to set up the analyzer to perform high power measurements.

### Setup

1. Turn off all of the equipment. Be sure that the jumpers between the PNA and test sets RCVR 1, RCVR 2 and CPLR THRU are disconnected at this time. This will protect the PNA from damage.
2. Connect the PNA jumpers for Port 1 and 2 SOURCE OUT and RCVR IN connectors.
3. Connect the [Agilent Technologies Z5623A Option H84](#) to the PNA, refer to [Figure 1-24, “Setup Configuration.”](#) Depending on your application set up, not all pulse pattern generators may be required as shown in this figure.

**Figure 1-24** Setup Configuration

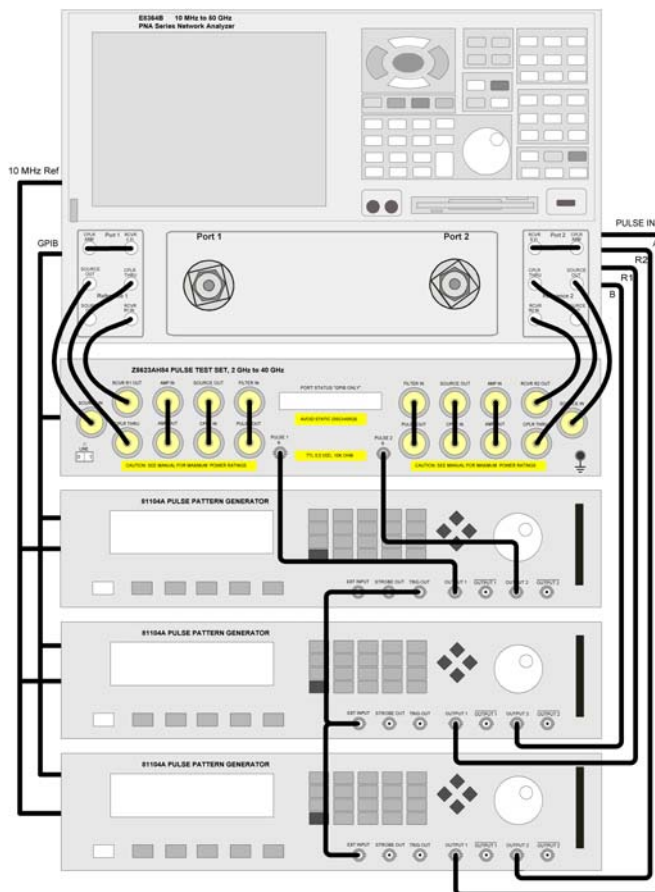

Z5623A Option H84  
 Making High Power Measurements With Option H84

4. If the [Agilent Technologies Z5623A Option H84](#) is in the Shipped mode configuration (all the jumpers are still on) remove the jumper between AMP OUT and AMP IN connectors on the front panel for Port 1. This can also be done for Port 2 if high power measurements are necessary for the reverse parameters of a device under test (DUT). Two booster amplifiers are required for both forward and reverse measurements. Refer to [Figure 1-25, “Connect Booster Amplifier.”](#)
5. Place four terminations on J1-J4 on the rear panel for AMP 1 and 2.
6. Verify that the Booster Amplifier is turned off at this time.
7. Connect the Booster Amplifier RF INPUT connector to the Port 1 AMP OUT connector on the front panel of the [Agilent Technologies Z5623A Option H84](#).
8. Remove the jumper on the [Agilent Technologies Z5623A Option H84](#) between SOURCE OUT and CPLR IN. Place an isolator or attenuator between the SOURCE OUT and CPLR IN on the port 2 side.

**Figure 1-25 Connect Booster Amplifier**

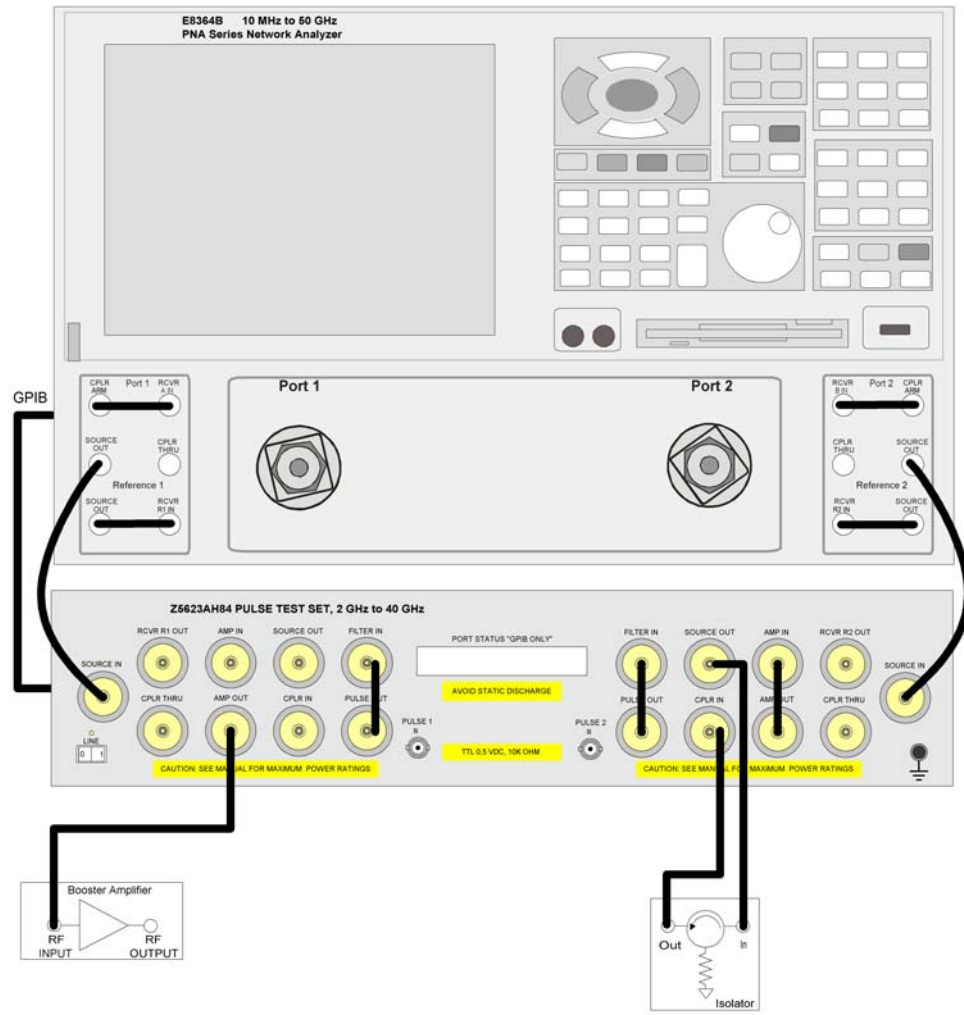

Z5623AH84\_HPFDBA1  
 Rev 1

## Determining Power Levels

Before continuing, save this state and set it up as the **User Preset** key. The User Preset Conditions can be found in the PNA Series Network Analyzer's help menu.

1. Press **[Menu/Dialog]** then tab to **Help**. Select **Network Analyzer Help**. Type in *User Preset*, this will describe how to setup a User Preset. The final state should be saved as the User Preset to avoid an over power condition from the factory preset.

To find the User Preset:

2. Press **[Menu/Dialog]** then tab to **System**. Scroll down to **User Preset**. Click on **User Preset Enable** and press **Save**, then **OK**. This will save the current state as **User Preset**.
3. Turn on the analyzer and decrease the power level to  $-20$  dBm by pressing **[Menu/Dialog]** then tab to **Channel**. In the pull down menu select **Power**. Scroll to **Port Selection** enter **[-20]**. Select **Port Power Coupled** to ensure that Ports 1 and 2 power levels are the same. Uncoupled ports should be used when adjusting the S12 power level or when Port 1 has a very low power level in comparison to Port 2.

---

**NOTE** Frequency Offset mode (Option 080) and External R1 (Option 081) must be activated when using the analyzer in a high power configuration. This will ensure phase lock and allow the R1 and R2 to receive the new reference power levels from the amplifiers.

- Press **[Menu/Dialog]** then tab to **Channel**. In the pull down menu select **Frequency Offset** and turn on the **Frequency Offset Mode**. In the Offset Setting set the **Offset** to **[0]**.
  - Press **[Menu/Dialog]** then tab to **Channel**. In the pull down menu select **Test Set**. Select the **External R1 Loop** in the R1 Input Path window.
4. Set the [Agilent Technologies Z5623A Option H84 Test Set](#) so that the external booster amplifier is in the RF path. Refer to "[Controlling the Test Set](#)" on page 22 to set the external Booster Amplifier to be engaged in the RF path.
  5. Turn on the booster amplifier.
  6. Measure the output power from the booster amplifier RF Output using a power meter and sensor.

---

**NOTE** Additional attenuation may have to be added between the coupler and the power meter, depending on the power used.

---

7. Verify the gain of the Booster Amplifier(s). For example, if the analyzer's output power level was set to  $-20$  dBm and the output power measured from the open end of the coupler was  $-5$  dBm, the gain of the booster amplifier would be  $+15$  dB.

8. Verify that the power measured in the previous steps is within the acceptable limits (less than +43 dBm for the AMP IN port). The maximum power level between 40 GHz and 50 GHz is +40 dBm.
9. Turn off the booster amplifier.
10. Estimate the maximum power level that will be needed to force the DUT into compression. Acceptable limits are less than +43 dBm for the AMP IN port. The maximum power level between 40 GHz and 50 GHz is less than +40 dBm.

---

**CAUTION** Do not command the test set to engage *or* disengage the amplifier from the Port 1 RF path while the amplifier is on. This can damage the internal RF switches in the test set.

---

11. Verify that the Booster Amplifier is turned off.
12. Connect the Booster Amplifier RF OUTPUT connector to the Port 1 AMP IN connector on the front panel of the [Agilent Technologies Z5623A Option H84](#).
13. Turn on the Booster Amplifier.
14. Using a high power meter and sensor, measure the output power from the test sets RCVR R1 port.
15. Turn off the Booster Amplifier.
16. Estimate the maximum power level that will be needed to force the DUT into compression.

## Selecting Power Ranges and Attenuator Settings

1. Select a power range that will not exceed the maximum estimated power level, but will force the DUT into compression. For example, if your Booster Amplifier has a gain of +15 dB and the DUT will compress if supplied with +15 dBm, then you would adjust the analyzer's output power not to exceed 0 dBm. This can be done by setting the Attenuator Control to 10 dB by pressing **Power**, under **Attenuator Control**, uncheck **Auto** and enter [10] into the entry area. In the "Port Selection" area, the Port Power Coupled can be checked to ensure that Port 1 and 2 power levels are the same, or unchecked if Port 1 and 2 power level requirements are different.
2. Estimate the maximum amount of gain that could be provided by the DUT and as a result, the maximum amount of power that could be received by Test Port 2 when the DUT is in compression. For example, if a DUT with a maximum gain of +10 dB receives an input of +10 dBm, then the maximum amount of power that could be received by Test Port 2 is +20 dBm. An isolator or attenuator may be required depending on the amount of power at Test Port 2. An isolator is placed between the CPLR IN and SOURCE OUT to protect the test set and the PNA.
3. Calculate the amount of attenuation needed between the analyzer's coupler and receiver so that you do not exceed the optimum receiver power level of -15 dBm. Refer to your PNA specifications to optimize power levels to the receiver ports.

It will be necessary to take the following into consideration:

- Power measured at the test sets RCVR R1 OUT = -2 dBm.
- Estimated compression power = -2 dBm.
- The optimum PNA receiver power level = -15 dBm.

Attenuation Equations:

4. Set the internal [Agilent Technologies Z5623A Option H84](#) Test Set RCVR R1 step attenuator to the value calculated below (rounding off to the highest 10 dB step). Refer to "[Controlling the Test Set](#)" on page 22 to set the Attenuator for RCVR R1 OUT path.

With the previous points in mind, the amount of attenuation can be calculated from the following equations:

$$\text{Attenuator RCVR R1 Setting} = -2\text{dBm} - (-15\text{ dBm}) = 13\text{ dBm}$$

$$\text{RCVR R1 Attenuator Value} = 20$$

5. Turn on the Booster Amplifier.
6. Measure the output power from the test sets RCVR R1 using a high power meter and sensor.
7. Verify that the power measured in the previous step is within the acceptable limits (-15 dbm at the RCVR R1 OUT).

8. Measure the output power from the test sets CPLR THRU port using a high power meter and sensor.
9. Turn off the Booster Amplifier.
10. Verify that the power measured in the previous step is within the acceptable limits (less than +43 dBm at the CPLR THRU port). The maximum power level between 40 GHz and 50 GHz is less than +40 dBm.
11. Calculate the amount of attenuation needed between the analyzer's coupler and receivers so that you do not exceed the optimum receiver power level of -15 dBm.

It will be necessary to take the following into consideration:

- Receiver A will be coupled to the analyzer RF path that could receive power reflections as high as +10 dBm.
  - Receiver B will be coupled to the analyzer RF path that could receive a maximum of +20 dBm from the DUT.
  - Analyzer coupler loss is -13 dB.
  - The optimum receiver power level is -15 dBm.
12. Set the internal step attenuator to the value calculated below (rounding off to the highest 5 dB step). Setting the receiver attenuation will set the internal attenuation. Press **[Menu/Dialog]** then tab to **Channel**. In the pull down menu select **Power**, under **Receiver Attenuation** set Receiver A to **[10]** and Receiver B to **[20]**. Power levels greater than +35 dBm will require additional attenuation between Port 2, access ports CPLR ARM and RCVR B IN.

With the previous points in mind, the amount of attenuation can be calculated from the following equations:

$$\text{Receiver Attenuator A} = 10 \text{ dBm} - 13 \text{ dBm} - (-15 \text{ dBm}) \quad \text{Attenuator A} = 12 \text{ dBm}$$

$$\text{Receiver Attenuator B} = 20 \text{ dBm} - 13 \text{ dBm} - (-15 \text{ dBm}) \quad \text{Attenuator B} = 22 \text{ dBm}$$



## Additional Setup

1. Remove the PNA SOURCE OUT and the RCVR IN jumpers.
2. Insert the jumpers between the PNA and the test set RCVR R1, RCVR R2, and CPLR THRU ports.
3. Turn on the Booster Amplifier.
4. Measure the output power from test Port 1 using a high power sensor. Verify that the power level is as expected.

**Figure 1-26** Connect PNA and Test Set Jumpers

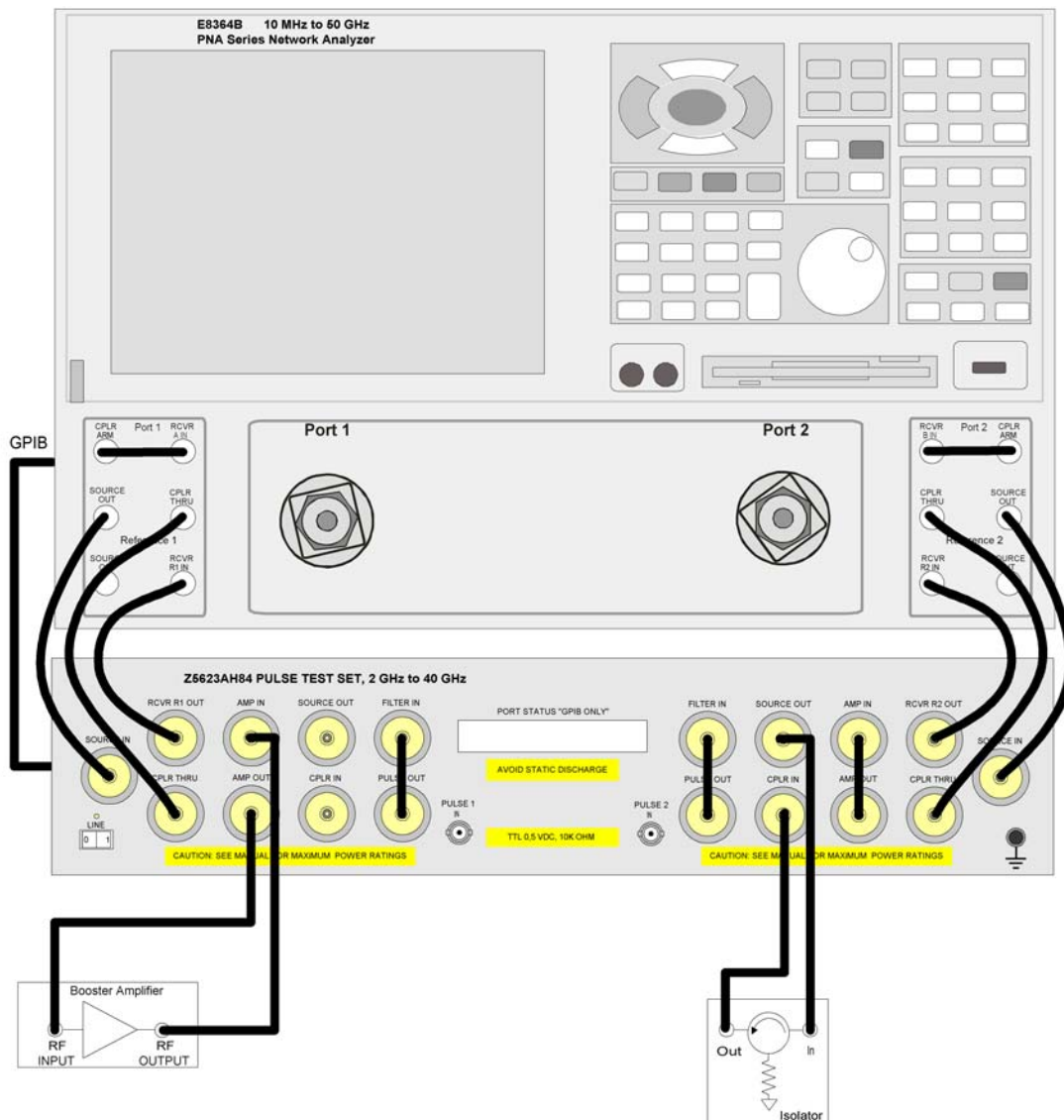

Z5623AH84\_HPFDBA2  
Rev 1

---

**CAUTION** Do *not* press Preset unless you have turned off the Booster Amplifier(s) or have saved this state and renamed it to User Preset. Pressing Preset will return the analyzer to its default power level and default internal attenuator settings. The increase in power may result in damage to the DUT or analyzer.

---

**CAUTION** High power isolators should be inserted between the SOURCE OUT and CPLR IN front panel ports on the test set if you are measuring a highly reflective device. The increase in power may result in damage to the analyzer.

---

## Final Setup and Response Calibration

1. Verify that all of the power and attenuator settings are correct, and set to the following measurement. Press **[Menu/Dialog]** then tab to **Trace**. In the pull down menu select **Measure** then **S21**.
2. Connect the analyzers test port cables to form a thru configuration.
3. Press **[Menu/Dialog]** then tab to **Calibration**. In the pull down menu select **Calibration Wizard** and then **Unguided Calibration Use Mechanical Standards**. Select **THRU Response**. Follow the analyzers window prompts to finish the calibration.
4. Make the connection as shown in [Figure 1-27](#).

**Figure 1-27** Connecting the DUT

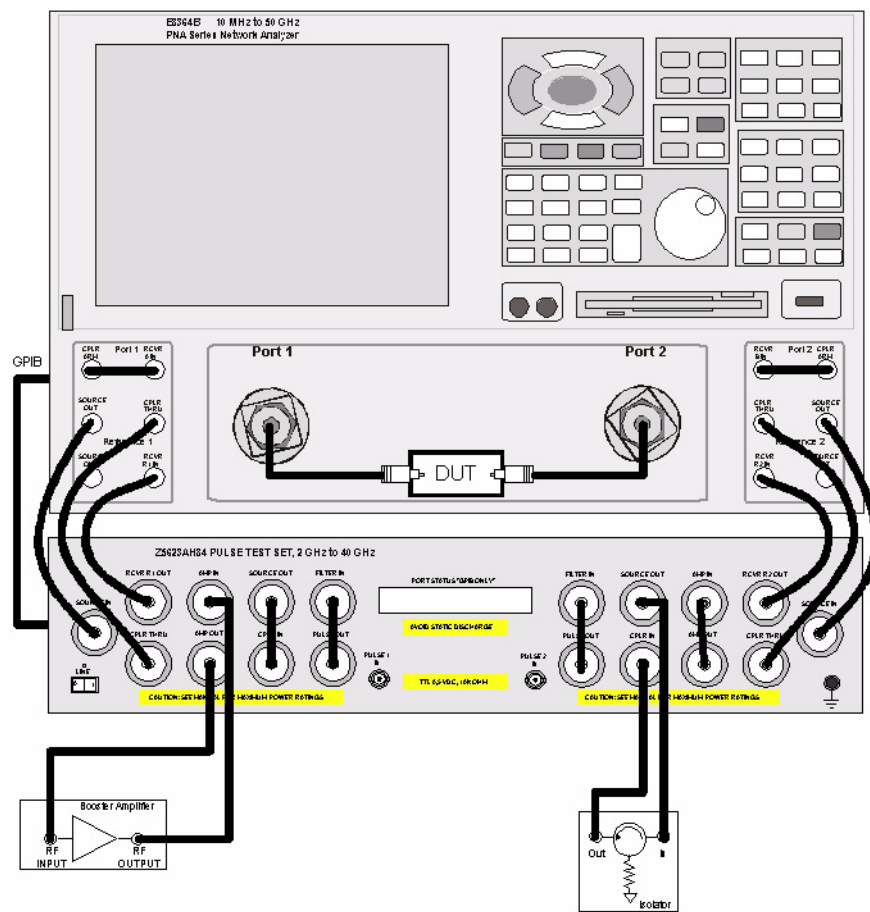

Z5623AH84\_connect\_DUT  
rev 1

5. Turn on the DUT and measure the S21 gain of the amplifier under test to confirm the proper operation of the measurement test setup.
6. Continue with any other high power measurements.

---

**NOTE** Ratio measurements, such as gain, will be correctly displayed. However, the displayed absolute power levels on the analyzer will *not* be correct. To correctly interpret power levels and the gain of the booster amplifier, the attenuator setting must be taken into consideration.

---

If no calibration has been performed or if the instrument is in an un-calibrated state, the following must be taken into consideration when interpreting the measured data:

- The value of attenuation added to receiver A and B.
- The R channel reference level supplied from the test set.
- Protection of the internal parts for the test set and PNA.

This procedure can be repeated to setup the reverse high power configuration.

---

## Test Set Internal Configurations

The Z5623AH84 can be internally configured to allow the user to configure it for different application requirements. In this section we will show the test sets internal configurations. The Test Sets Port 1 side is a mirror image of the Port 2 side. Both sides are independent of each other.

For simplicity the Port 1 side will be used for the following examples.

There are four basic mode configurations:

- Bypass
- High Power
- Pulse
- Pulse High Power
- Amplifier Terminate

### Bypass

The bypass mode sets the Test Set's internal switches so that the SOURCE IN port thru path connects directly to the CPLR THRU port. This allows you to use the PNA in a normal operation. The test port and R1 reference power at the PNA will be reduced due to the loss of the test set. [Figure 1-28](#) shows the main signal flow through the test set Port 1 side, which is identical to the Port 2 side.

**Figure 1-28** Bypass

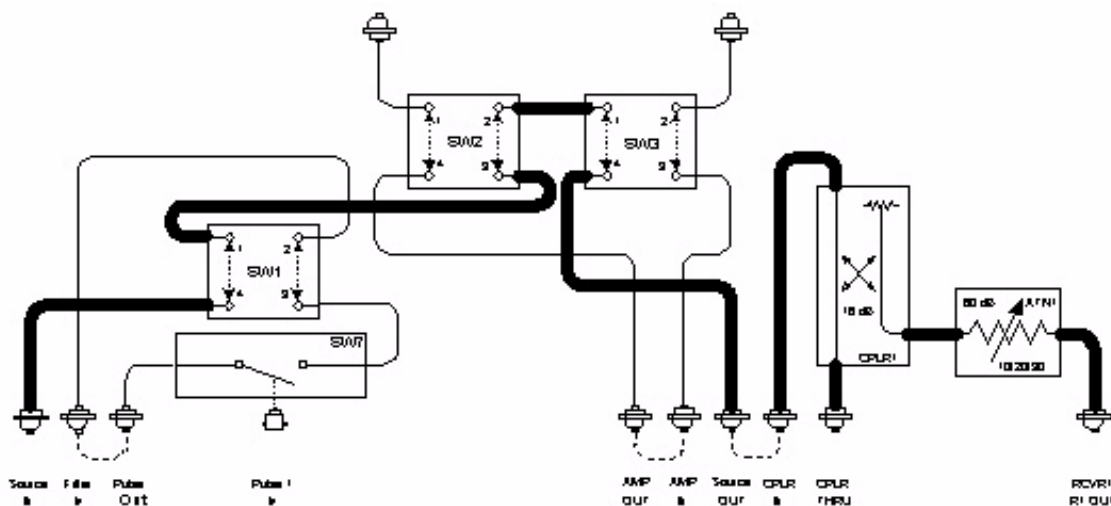

## High Power

The high power mode sets the Test Set's internal switches so that the SOURCE IN port thru path connects to the AMP OUT and AMP IN ports, and then to the CPLR THRU port. This allows the user to insert a Booster Amplifier in the RF path. Figure 1-29 shows the main signal flow through the test set Port 1 side, which is identical to the Port 2 side.

Figure 1-29 High Power

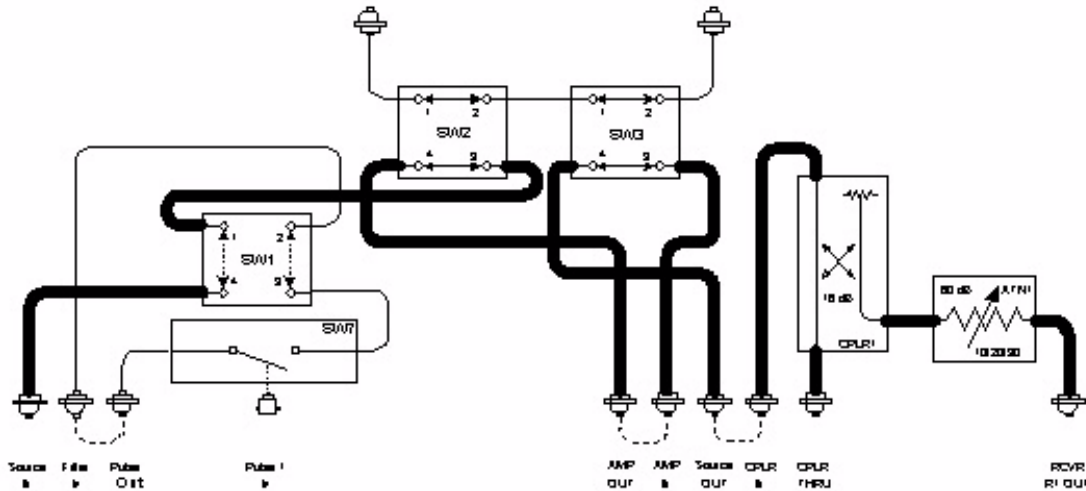

## Pulse

The pulse mode sets the Test Set's internal switches so that the SOURCE IN port thru path connects to the PIN switch modulator, directly to the CPLR THRU port. This allows the user to make lower power pulse measurement. Figure 1-30 shows the main signal flow through the test set Port 1 side, which is identical to the Port 2 side.

Figure 1-30 Pulse

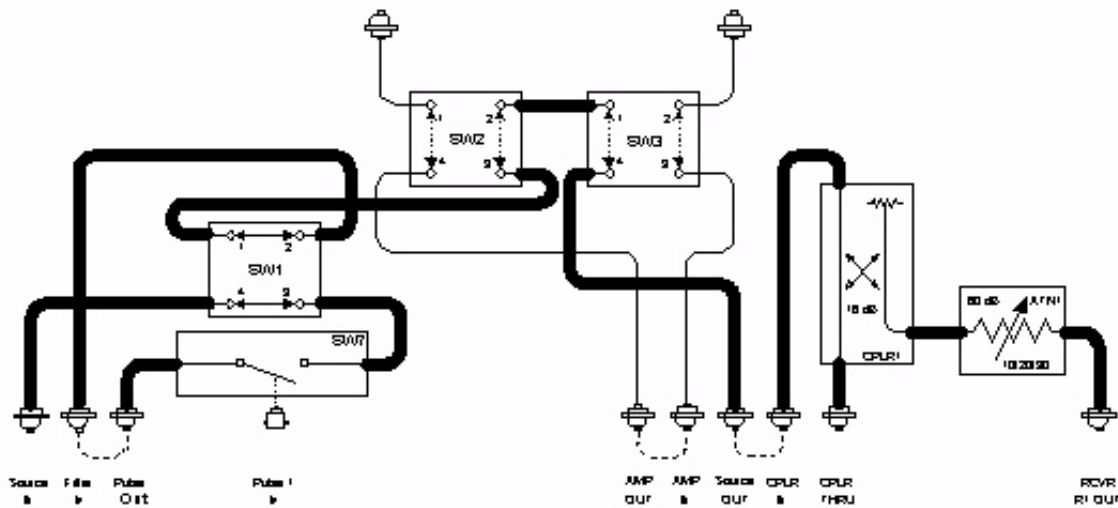

## Pulse High Power

The pulse high power mode sets the Test Set's internal switches so that the SOURCE IN port thru path connects to the PIN switch modulator, then to the AMP OUT and AMP IN ports, and then to the CPLR THRU port. This allows user to insert a booster amplifier in the pulsed RF path. [Figure 1-31](#) shows the main signal flow through the test set Port 1 side, which is identical to the Port 2 side.

**Figure 1-31 Pulse High Power**

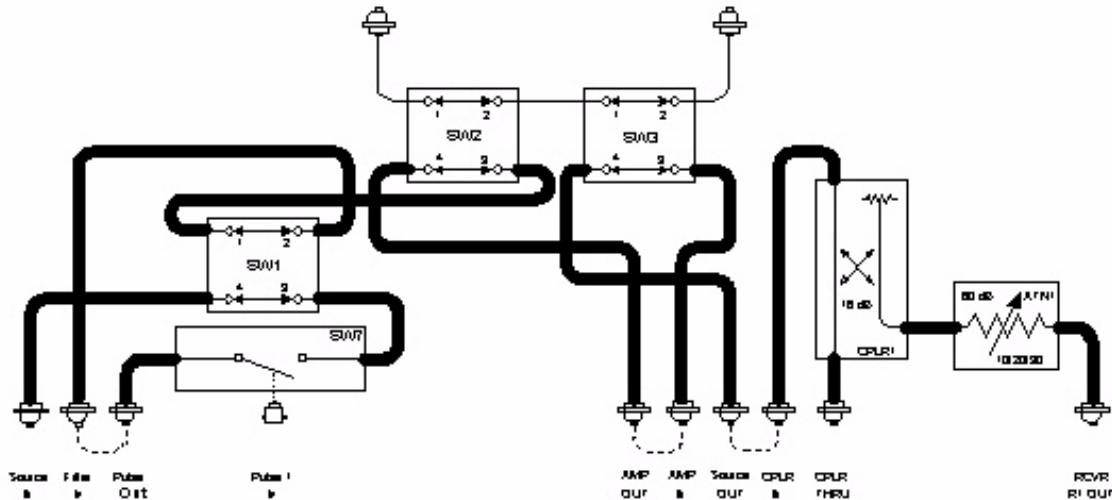

## Amplifier Terminate

The terminate amplifier is set in the bypass and pulse mode. This sets the Test Set's internal switches so that the AMP IN and AMP OUT RF ports are routed to the rear panel Amp Term 1 ports. Customer furnished terminations can be connected to these ports so that you may customize your power requirements. This allows the user to terminate the Booster Amplifiers input and output. [Figure 1-32](#) shows the main signal flow through the test set Port 1 side, which is identical to the Port 2 side.

**Figure 1-32 Amplifier Termination**

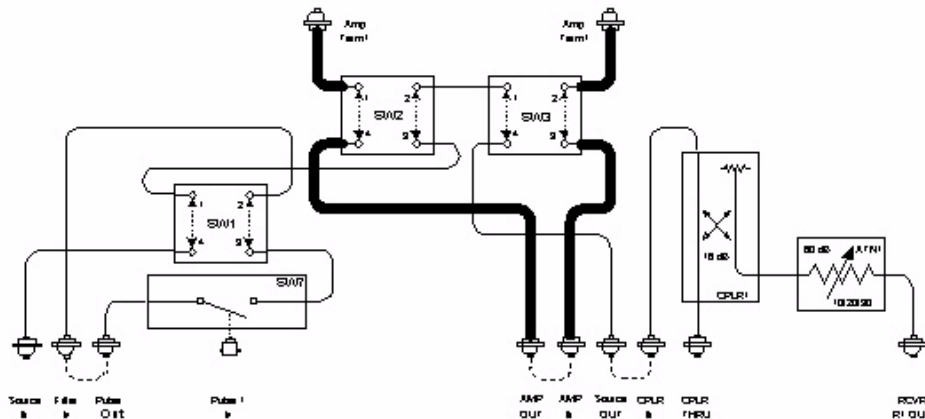

## Specification

Specifications for the [Agilent Technologies Z5623A Option H84](#) Dual Directional Pulse Test Set are nominal.

### Pulsed RF PIN Switch Detectors

Transition Time: 30 nanoseconds; TYPICAL 20 nanoseconds

Rise/Fall Time (10% to 90%): 10 nanoseconds; TYPICAL 8 nanoseconds

Pulse Width (minimum): 100 nanoseconds

Trigger Level (External): 10 k $\Omega$  TTL, "0" ON, "1" OFF, TTL-low-level signal turns RF on.

Maximum Power Input: 20 dBm

On/Off Ratio: 70 dB (typically > 90 dB, 400 MHz to 2 GHz)

Frequency Range: 2 to 40 GHz

### E8363B/E8364B RF PIN Switch Modulator

Widest Bandwidth: 10 kHz

Trigger Level (External): TTL



Trigger Width (minimum): 20 nanoseconds

**Table 1-7 Nominal System Performance**

Item		Unit of Measure			
Nominal system Performance (Not tested at this time)		0.01 to 8 GHz	8 to 20 GHz	20 to 40 GHz	40 to 50 GHz
Maximum Power at Port 1 <sup>a</sup> (nominal)		-25 dBm	-30 dBm	-35 dBm	-40 dBm
Reference Power at Port 1 (nominal)		-38 dBm <sup>b</sup>	-43 dBm	-48 dBm	-53 dBm
Minimum Power at Port 1 <sup>c</sup> (nominal)		-80 dBm	-80 dBm	-80 dBm	-80 dBm
System Dynamic Range <sup>d</sup> (bypass mode)		110 dB	100 dB	90 dB	85 dBm
System Dynamic Range <sup>d</sup> (pulse mode)		Pulse <sup>e</sup>	70 dB <sup>f</sup>	70 dB	60 dB
		Non-Pulse <sup>e</sup>	80 dB <sup>f</sup>	80 dB	80 dB

- a. This maximum power measurement assumes that the PNA source attenuator is set to 0 dB and the power level is set to -17 dBm (default power level for the E8363B and E8364B).
- b. Excludes frequencies below 1 GHz due to test sets RCVR Out Coupler. Frequencies below 1 GHz are nominally -3 dB at 500 MHz, -15 dB at 100 MHz, and -20 dB at 50 MHz from measured performance at 1 GHz.
- c. This minimum power measurement is in bypass mode.
- d. Forward transmission measurements. Limited by compression level and noise floor.
- e. System Dynamic Range “Pulse” indicates the ON/OFF ratio of the PIN switch. The Non Pulse indicates when the PIN switch is ON and not used in a pulse mode application.
- f. Excludes performance below 2 GHz.

## Test Set Performance Verification

### Equipment Required

- E8363B/E8364B Network Analyzer 10 MHz to 50 GHz or equivalent
- 85056A Calibration kit or equivalent
- 81110A with 81111A Pulse Pattern Generator
- (2) 2.4 mm RF cables (36 inch or equivalent)
- 86100A Infinium DCA Wideband Oscilloscope (or equivalent)
- 83484A Two Channel 50 GHz Module (or equivalent)

## Procedure

To test the performance of the [Agilent Technologies Z5623A Option H84](#) this document assumes that the user is familiar with the necessary equipment. The PNA USB keyboard and mouse will be necessary to enter GPIB commands and to read the trace data. Measurements can be made easier by setting up Markers with search, tracking and search domain user states for each of the frequency bands.

Using the PNA as the controller to issue commands to the [Agilent Technologies Z5623A Option H84](#) Test Set can be found in “[Controlling the Test Set](#)” on page 22.

General S-Parameters are used to characterize the connection paths of the test set. Both reflection and transmission measurements are required. These measurements are made with the E8363B, 2.4 mm cal kit and RF cables. Power Output and Pulse Shape are not measured to re-verify the [Agilent Technologies Z5623A Option H84](#) test set.

A Full 2-Port SLOT (Short, Load, Open, Thru) Calibration should be performed on the PNA at the ends of the RF cables. The Isolation must not be omitted. The calibration should be performed at the following settings shown in [Table 1-8](#).

**Table 1-8**            **Calibration Settings**

Start freq	10 MHz	Stop Freq	50 GHz
Power level	-17 dbm	IF bandwidth	100 Hz
Number of points	401		

### CPLR Thru S-Parameters

1. Connect the RF cables as shown in [Figure 1-33, “CPLR Thru S-Parameters,”](#) which shows the configuration for Port 1 and 2 setup. This measures the Source In to CPLR THRU S-Parameters and On/Off Ratio for Port 1 and 2. Connect Port 1 and 2 recording the data in [Table 1-9 on page 60](#). Perform Port 1 first.
2. Connect a 50 Ω load to the RCVR Out Port.
3. Set the [Agilent Technologies Z5623A Option H84 Test Set](#) to the Bypass mode using the PNA as the controller. Measure the S-Parameters for the Source In to CPLR THRU. Record the performance data in [Table 1-9](#).
4. Verify that the Pulse In is set to 0 Volts on the 81111A and set the impedance on the Output to 1000 Ω
5. Set the Test Set to the High Power mode using the PNA as the controller. Measure the S-Parameter for the Source In to CPLR THRU. Record the data in [Table 1-9](#).
6. Set the Test Set to the High Power Pulse mode using the PNA as the controller. Measure the S-Parameter for the Source In to CPLR THRU. Record the data in [Table 1-9](#) for frequencies between 2 to 40 GHz only.
7. Set the Test Set to the Pulse mode using the PNA as the controller. Measure the S-Parameter for the Source In to CPLR THRU. Record the data in [Table 1-9](#) for frequencies between 2 to 40 GHz only.
8. Repeat [step 2](#) through [step 7](#) for Port 2.

**Figure 1-33 CPLR Thru S-Parameters**

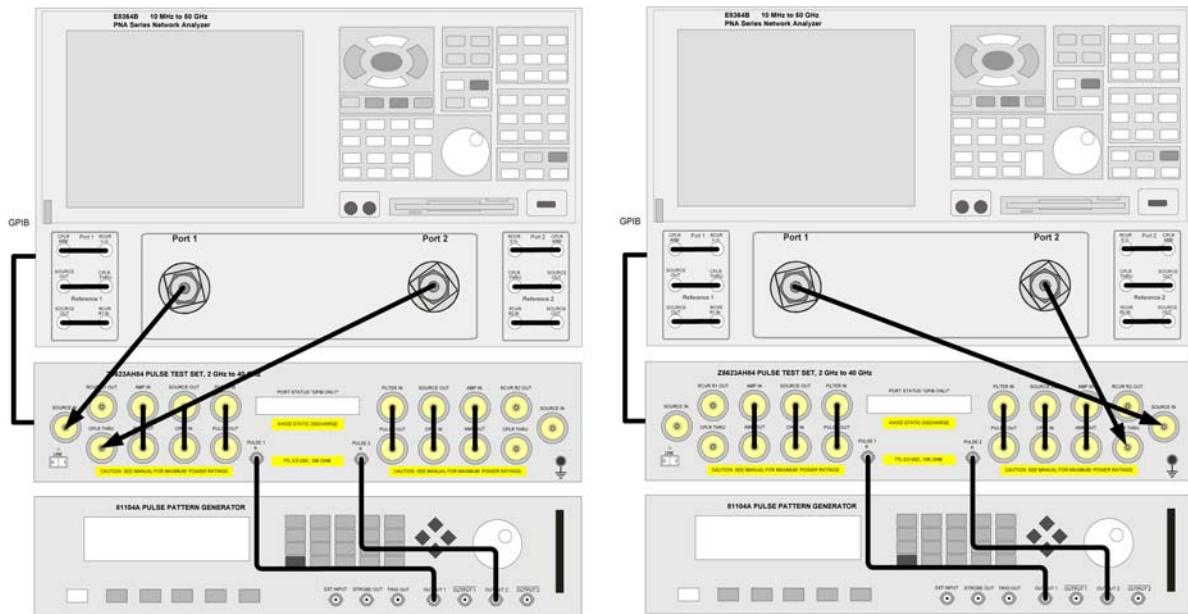

Z5623AH84\_on\_off  
Rev\_1

## RCVR Port S-Parameters

1. Connect the RF cables as shown in [Figure 1-34, “RCVR Port S-Parameters,”](#) which shows the configuration for Port 1 and 2 setup. This measures the Source In to REF 1 OUT S-Parameters for the Port 1 and 2. Perform Port 1 and then Port 2. Record the data in [Table 1-10 on page 61.](#)
2. Set the [Agilent Technologies Z5623A Option H84 Test Set](#) to the Pulse mode using the PNA as the controller. Measure the S-Parameters for the Source In to REF OUT. Record the data in [Table 1-10](#) for frequencies between 2 to 40 GHz only.
3. Connect a 50  $\Omega$  load to the CPLR Thru Port.
4. Verify that the Pulse In is set to 0 Volts on the 81111A and set the impedance on the Output to 1000  $\Omega$
5. Set the Test Set to the High Pulse mode using the PNA as the controller. Measure the S-Parameter for the Source In to REF OUT. Record the data in [Table 1-10.](#)
6. Set the Test Set to the High Power mode using the PNA as the controller. Measure the S-Parameter for the Source In to REF OUT. Record the data in [Table 1-10.](#)
7. Set the Test Set to the Bypass mode using the PNA as the controller. Measure the S-Parameter for the Source In to REF OUT. Record the data in [Table 1-10.](#)
8. Repeat [step 2](#) through [step 7](#) for Port 2.

**Figure 1-34 RCVR Port S-Parameters**

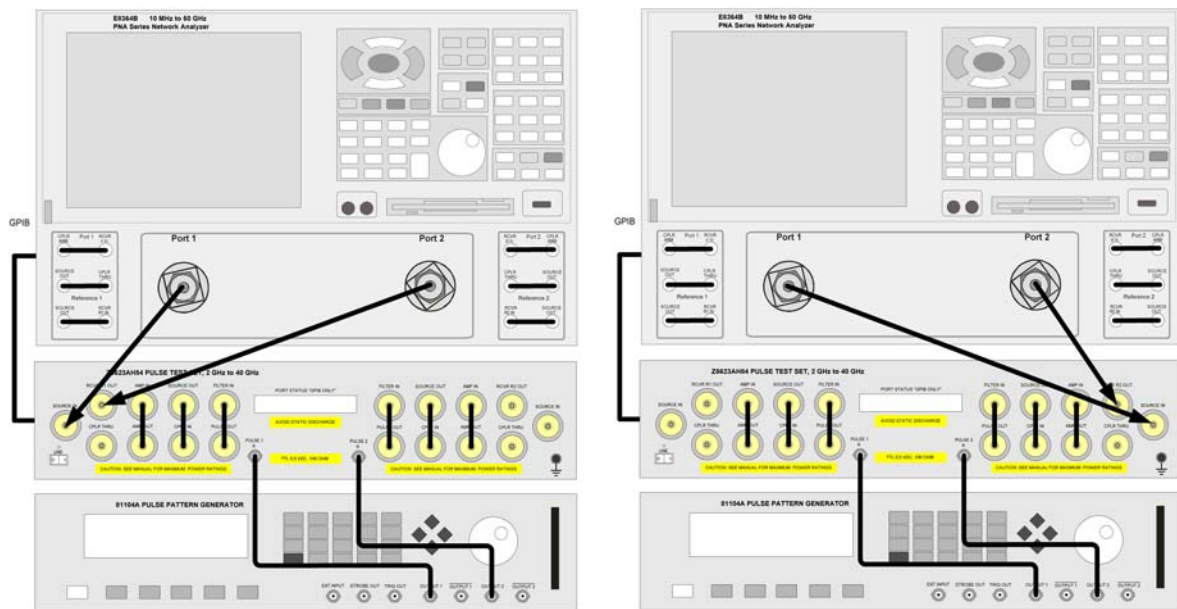

## On/Off Switch Ratio

1. Connect the RF cables as shown in [Figure 1-35, “On/Off Switch Ratio,”](#) which shows the configuration for Port 1 and 2 set up. This measures the Source In to REF 1 OUT S-Parameters and Reference Attenuators for Port 1 and 2. Perform Port 1 first. Record the data in [Table 1-11 on page 62](#).
2. Verify that the Pulse In is set to 0 Volts on the 81111A and set the impedance on the Output to 1000  $\Omega$
3. Set the [Agilent Technologies Z5623A Option H84 Test Set](#) to the Pulse mode using the PNA as the controller. Measure the S-Parameter for the Source In to Pulse Out. Record the data in [Table 1-11](#).
4. Set the PNA to measure S21 only. Normalize the S21 response.
5. Set the Pulse In to 5 Volts by changing the 81111A Output to 5 Volts.
6. Measure the On/Off Ratio. Record the data in [Table 1-11](#).
7. Repeat [step 2](#) through [step 6](#) for Port 2.

**Figure 1-35 On/Off Switch Ratio**

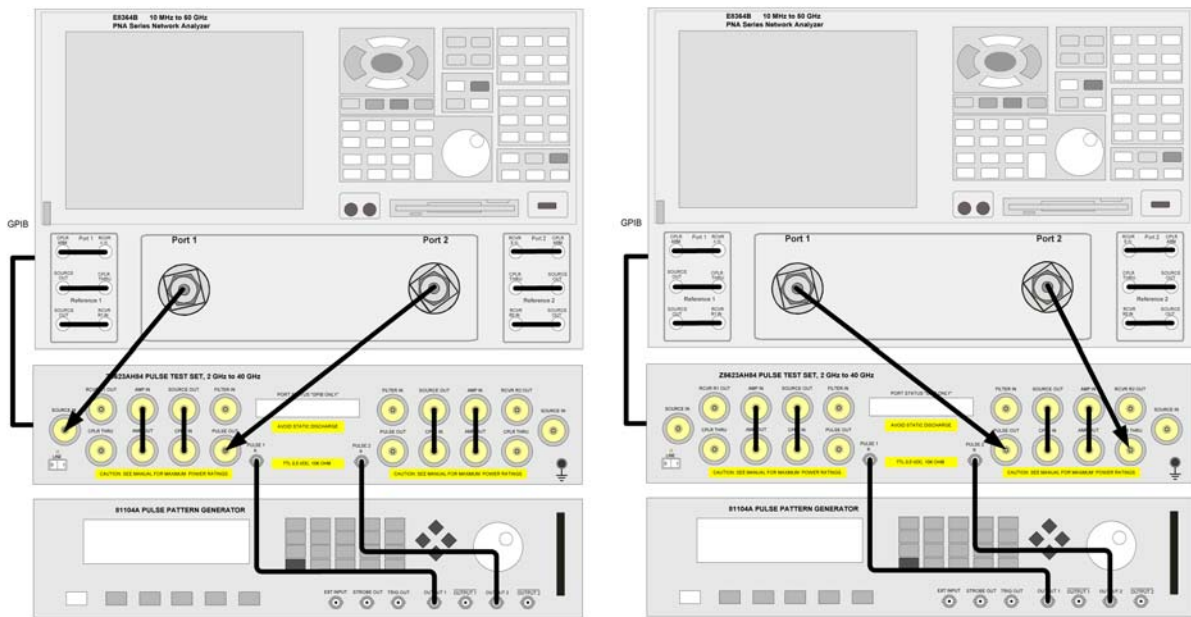

Z5623AH84\_on\_off  
Rev\_1

## Attenuator Settings

1. Connect the RF cables as shown in [Figure 1-36, “Attenuator Steps,”](#). This configuration measures the CPLR IN to REF 1 OUT Reference Attenuators for Port 1 and 2. Perform Port 1 first. Record the data in [Table 1-11 on page 62](#).
2. Connect a 50  $\Omega$  load to the CPLR Thru Port.
3. Set the PNA to measure S21 only. Normalize the S21 response.
4. Set Marker 1 to 2 GHz. The attenuator setting is measured at 2 GHz only to test the attenuators relative attenuation for each setting. The noise floor of the PNA limits measurements when the test sets attenuator setting is greater than 40 dB. Frequencies above 6 GHz at low power levels make measurements difficult. Frequencies below 1 GHz are also difficult due to the coupler roll off.
5. Set the [Agilent Technologies Z5623A Option H84 Test Set Reference Attenuator](#) in 10 dB steps (10 - 60 dB) and measure the response. Record the data in [Table 1-11](#).
6. Repeat [step 2](#) through [step 5](#) for Port 2.

**Figure 1-36 Attenuator Steps**

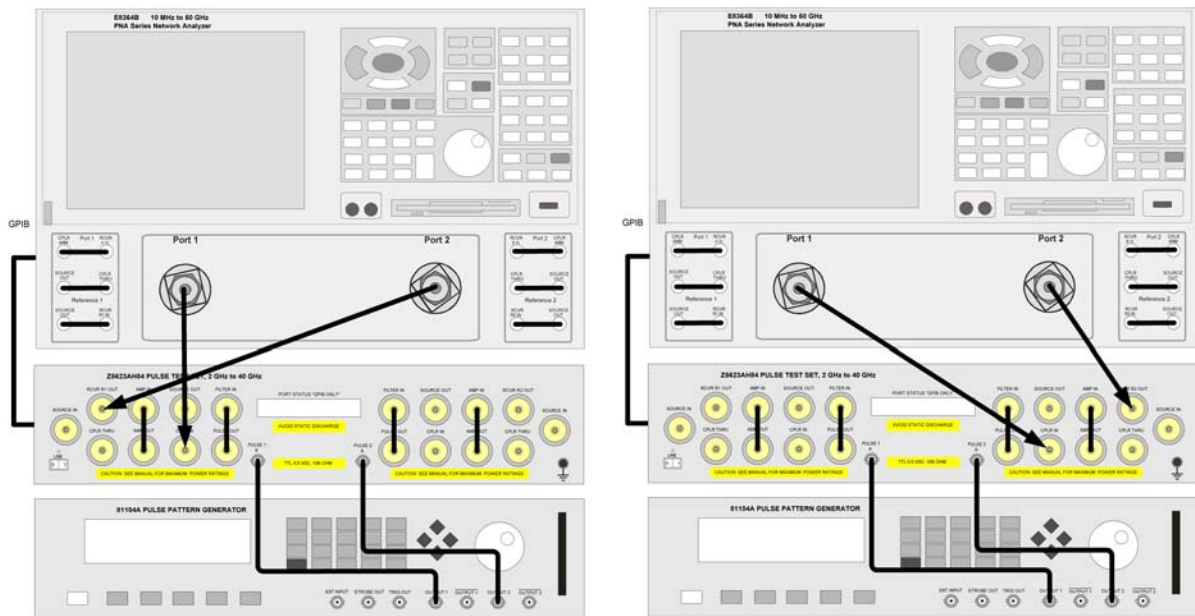

### Rear Panel Termination Test

1. Connect the 50 Ω loads to the rear panel connectors J1, J2, J3, and J4.
2. Set the PNA to measure S11 and S22.
3. Set the [Agilent Technologies Z5623A Option H84](#) Test Set to the Bypass mode using the PNA as the controller. Measure the S-Parameter to the Amp In and Amp Out for J4 and J3. Record the data in [Table 1-11 on page 62](#).
4. Repeat this procedure for the Port 2 side and record the data for J2 and J1.

**Figure 1-37 Rear Panel Termination**

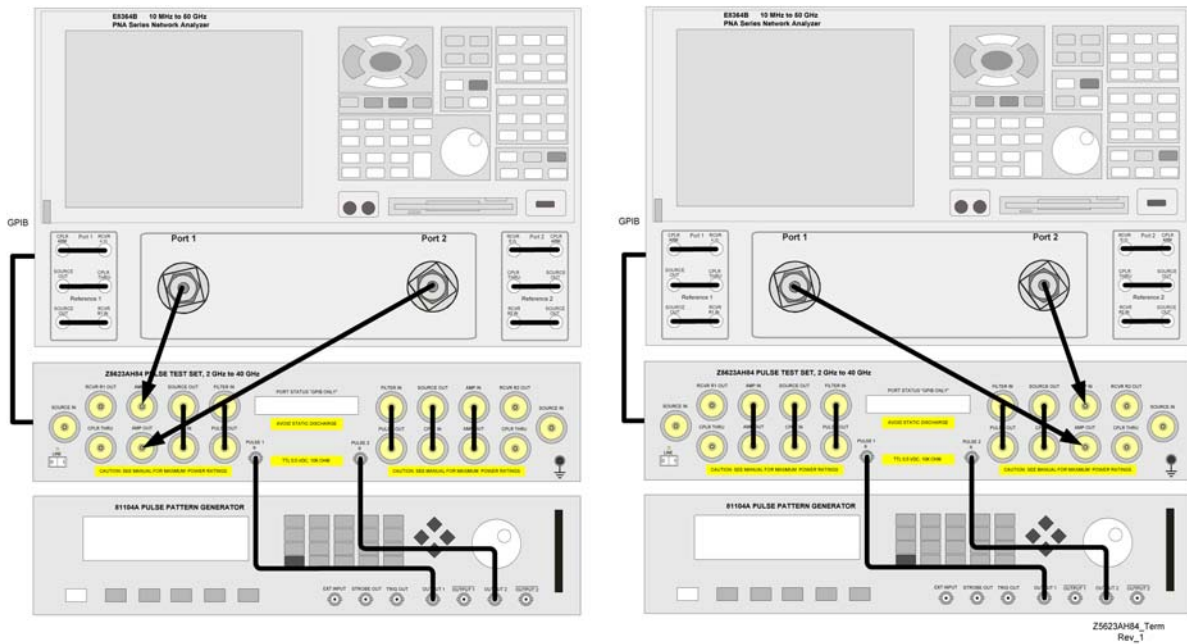



### Rise and Fall Time Test

1. Connect the RF cables shown in [Figure 1-40 on page 59](#). This configuration measures the rise and fall times of the PIN switch modulators in the test set. Record the data in [Table 1-11 on page 62](#).
2. Set the E8363/64B to **[CW mode] [Frequency] [20 GHz]**.
3. Set the E8363/64B **[Power Level] [-20 dBm]**.
4. Turn the 81110A Output 1 **On**.
5. Set the 81110A **[LEVEL] Normal > High 5 Volts > Low 0 Volts > 50 to 1 kΩ**
6. Set the 81110A **[TRIGGER MODE] to Continuous > Pulse Signal to Output 1 > Pulse Period to Internal Osc.**
7. Set the 81110A **[TIMING] to Freq 100 kHz > Delay 0 ns > Duty Cycle 90% > LeadEdge 2 ns > TrailingEdge = LeadEdge.**
8. Set the 81110A **[PATTERN] to Update Continuous > CH1 to 1.**
9. Set the 86100A for **Channel 1 On > Scale to 10 mv > Time to 2 μs**. Position the pulse to the right edge of display.
10. Expand the **Time** scale to measure the pulse amplitude at 100 ns. You may need to reposition the pulse to keep the rising edge on the display.
11. Measure the amplitude of the Positive pulse side by setting the **solid horizontal marker** to the center of the trace 0 Volts. Set the **dash horizontal marker** to the maximum Positive Pulse amplitude. Measure the delta voltage. The following equation will allow you to calculate the 10% and 90% rise and fall time.

$$10\% \text{ point} = \text{delta (positive pulse)} \times 0.1$$

$$90\% \text{ point} = \text{delta (positive pulse)} \times 0.9$$

**Figure 1-38 Delta Voltage**

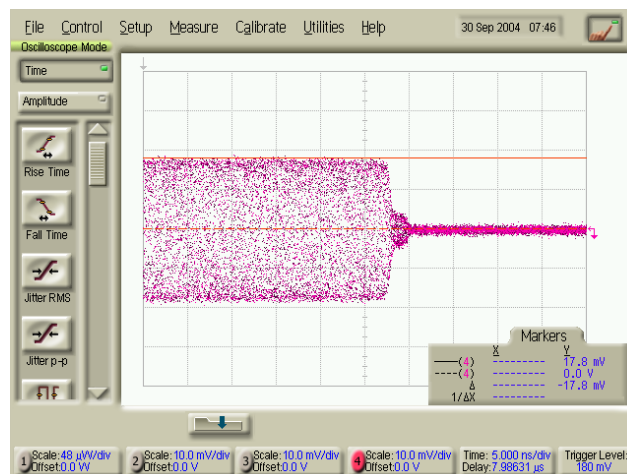

12. Set the **solid horizontal marker** to the 10% point and the **dash horizontal marker** to the 90% point.
13. Expand the **Time scale** of the oscilloscope for **5 ns**, keeping the pulses rise time in view.
14. Set the **vertical solid marker** to the 10% point and the **vertical dash marker** to 90%, and measure the rise time by reading the delta vertical Marker. Record the rise time in [Table 1-11](#).
15. Increase the Time scale to 100 ns. Position the Marker on the pulses fall time to the right on the display and then expand the scale to 5 ns keeping the pulse fall time in view.
16. Set the **vertical solid marker** to the 90% point and the **vertical dash marker** to 10%, measure the fall time by reading the delta vertical marker. Record the fall time in [Table 1-11](#).

**Figure 1-39**      **Fall Time**

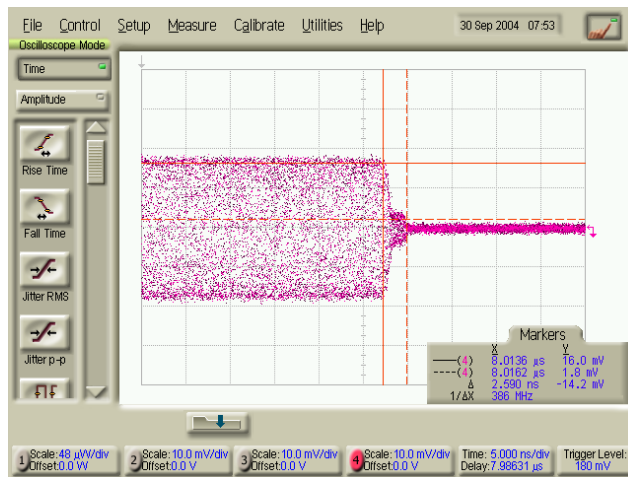

17. Repeat [step 9](#) through [step 16](#) for 30 GHz and 40 GHz by changing the CW frequency on the E8363/64B and measure the rise and fall times. Insure that the correct High Pass or Band Pass filter is in place.

Z5623A Option H84  
Specification

Figure 1-40 Rise and Fall Time Setup

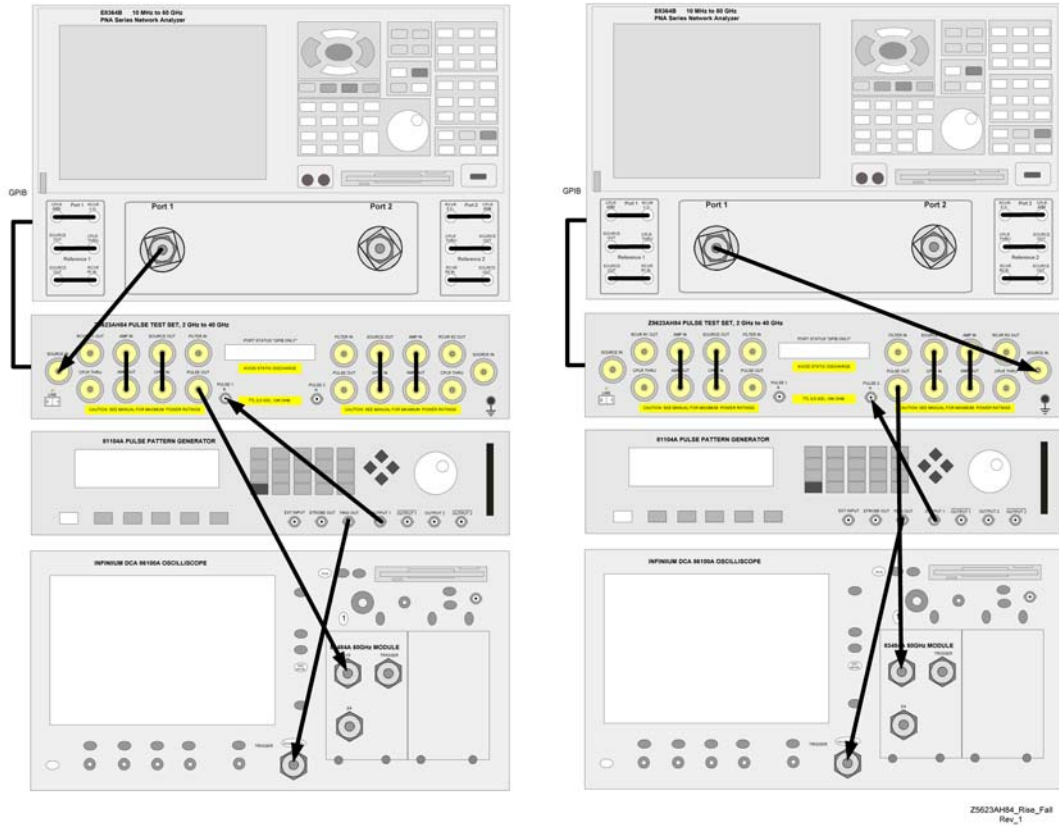

**Table 1-9 Performance Data (Port 1 & 2 to CPLR THRU)**

Port/Connection/Mode	0.01 to 8.0 GHz		8.0 to 20.0 GHz		20.0 to 40.0 GHz		40.0 to 50.0 GHz	
	Spec (dB)	Meas	Spec (dB)	Meas	Spec (dB)	Meas	Spec (dB)	Meas
<b>Port 1 SOURCE IN to CPLR THRU<sup>a</sup></b>								
Bypass								
S11, S22	18		12		11		11	
S21, S12	-6		-10		-14		-16	
High Power								
S11, S22	18		12		11		11	
S21, S12	-8		-12		-17		-20	
High Power Pulse								
S11, S22	8		6		6		n/a	n/a
S21, S12	-16		-22		-26		n/a	n/a
Pulse								
S11, S22	8		6		6		n/a	n/a
S21, S12	-16		-20		-24		n/a	n/a
<b>Port 2 SOURCE IN to CPLR THRU<sup>a</sup></b>	Spec (dB)	Meas	Spec (dB)	Meas	Spec (dB)	Meas	Spec (dB)	Meas
Bypass								
S11, S22	18		12		11		-11	
S21, S12	-6		-10		-14		-16	
High Power								
S11, S22	18		12		11		-11	
S21, S12	-8		-12		-17		-20	
High Power Pulse								
S11, S22	8		6		6		n/a	n/a
S21, S12	-16		-22		-26		n/a	n/a
Pulse								
S11, S22	8		6		6		n/a	n/a
S21, S12	-16		-20		-24		n/a	n/a

a. Pulse path measurement specifications start at 2 GHz.

**Table 1-10 Performance Data (Port 1 & 2 to RCVR R1 & R2 OUT)**

Port/Connection/Mode	0.01 to 8.0 GHz		8.0 to 20.0 GHz		20.0 to 40.0 GHz		40.0 to 50.0 GHz	
	Spec (dB)	Meas	Spec (dB)	Meas	Spec (dB)	Meas	Spec (dB)	Meas
<b>Port 1 SOURCE IN to RCVR R1 OUT<sup>ab</sup></b>								
Pulse								
S11, S22	8		6		6		n/a	n/a
S21, S12	-30		-35		-35		n/a	n/a
High Power Pulse								
S11, S22	8		6		6		n/a	n/a
S21, S12	-30		-40		-44		n/a	n/a
High Power								
S11, S22	18		12		11		11	
S21, S12	-23		-27		-30		-32	
Bypass								
S11, S22	18		12		11		11	
S21, S12	-21		-25		-27		-28	
<b>Port 2 SOURCE IN to RCVR R2 OUT<sup>ab</sup></b>	Spec (dB)	Meas	Spec (dB)	Meas	Spec (dB)	Meas	Spec (dB)	Meas
Pulse								
S11, S22	8		6		6		n/a	n/a
S21, S12	-30		-35		-35		n/a	n/a
High Power Pulse								
S11, S22	8		6		6		n/a	n/a
S21, S12	-30		-40		-44		n/a	n/a
High Power								
S11, S22	18		12		11		11	
S21, S12	-23		-27		-30		-32	
Bypass								
S11, S22	18		12		11		11	
S21, S12	-21		-25		-27		-28	

- a. RCVR R1 & R2 OUT measured from 1 to 50 GHz due to internal coupler roll off below 1 GHz. The roll off adds -3 dB at 500 MHz, -15 dB at 100 MHz, and -20 dB at 50 MHz from the measured response value at 1 GHz.
- b. Pulse path measurement specifications start at 2 GHz.

**Table 1-11 Performance Data (On/Off, Attenuation, Rise and Fall)**

Port/Connection/Mode	2 to 8.0 GHz		8.0 to 20.0 GHz		20.0 to 40.0 GHz		40.0 to 50.0 GHz	
<b>On/Off Switch Ratio Normalized S21 Response</b>	Spec (dB)	Meas	Spec (dB)	Meas	Spec (dB)	Meas	Spec (dB)	Meas
Port 1 side (typically 90 dB, 400 MHz to 2 GHz)	70		70		60		n/a	n/a
Port 2 side (typically 90 dB, 400 MHz to 2 GHz)	70		70		60			
<b>Attenuator Setting<sup>a</sup> Normalized S21 Response</b>	Specification ± 3.5 dB				Measured Value			
Port 1 Side								
10	10							
20	20							
30	30							
40	40							
50	50							
60	60							
Port 2 Side								
10	10							
20	20							
30	30							
40	40							
50	50							
60	60							
<b>Rear Panel Match</b>	J4 (AMP IN)		J3 (AMP OUT)		J2 (AMP IN)		J1 (AMP OUT)	
	Spec (S22 dB)	Meas	Spec (S11 dB)	Meas	Spec (S22 dB)	Meas	Spec (S11 dB)	Meas
<b>AMP IN/OUT Term Ports</b>	8		8		8		8	
<b>Rise and Fall Time</b>	Rise Time Spec (ns)		Meas		Fall Time Spec (ns)		Meas	
Port 1 Side								
< 20 GHz	10				10			
30 GHz	10				10			
40 GHz	10				10			
Port 2 Side								
< 20 GHz	10				10			
30 GHz	10				10			
40 GHz	10				10			

a. Marker 1 data measured at 2 GHz only with 0 dB attenuation in the RCVR Out path normalized. This is a functional check only.

---

## Replaceable Parts

**Table 1-12**      **Replaceable Parts List**

Reference Designator	Description	Agilent Part Number
	PWR-SPLY; power-110W; number of Outputs = 4	0950-2252
ATTN1-ATTN2	Attenuator assembly (60 dB 3-Section)	33325-60006
FP/RP RF Conn	Connector assembly (bulkhead)	5062-7243
CPLR1-CPLR2	Coupler (50 GHz)	5068-7658
	Daughter controller board	87050-60324
	Board assy interim	87050-63149
SW1-SW6	50 GHz transfer switch	87222-60015
	Pulse bias board assy	Z5623-63293
	Manual control interface assembly	Z5623-63364
SW7-SW8	U-Wave PIN diode switch (2 to 40 GHz)	Z5623-80031
	User's and Service Guide (Option H84)	Z5623-90066

Z5623A Option H84  
**Replaceable Parts**





---

## Safety and Regulatory Information

### Introduction

Review this product and related documentation to familiarize yourself with safety markings and instructions before you operate the instrument. The documentation contains information and warnings that must be followed by the user to ensure safe operation and to maintain the product in a safe condition.

### Connector Care and Cleaning

If alcohol is used to clean the connectors, the power cord to the instrument must be removed. All cleaning should take place in a well ventilated area. Allow adequate time for the fumes to disperse and moist alcohol to evaporate prior to energizing the instrument.

---

**WARNING**

**To prevent electrical shock, disconnect the Agilent Technologies model product from mains before cleaning. Use a dry cloth or one slightly dampened with water to clean the external case parts. Do not attempt to clean internally.**

---

### Before Applying Power

Verify that the product is configured to match the available main power source. If this product is to be powered by autotransformer, make sure the common terminal is connected to the neutral (grounded) side of the ac power supply.

### Shipping Instructions

You must always call the Agilent Technologies Instrument Support Center to initiate service before retuning your instrument to a service office. Refer to [“Contacting Agilent” on page 71](#). Always transport or ship the instrument using the original packaging if possible. If not, comparable packaging must be used. Attach a complete description of the failure symptoms.

### Compliance with Canadian EMC Requirements

This ISM device complies with Canadian ICES-001.  
Cet appareil ISM est conforme a la norme NMB du Canada.

## Compliance with German Noise Requirements

This is to declare that this instrument is in conformance with the German Regulation on Noise Declaration for Machines (Laermangabe nach der Maschinenlaermrrordnung-3. GSGV Deutschland).

Acoustic Noise Emission/Geraeuschemission	
LpA<70 dB	Lpa<70 dB
Operator Position	am Arbeitsplatz
Normal Operation	normaler Betrieb
per ISO 7779	nach DIN 45635 t. 19

## Declaration of Conformity

For a copy of the manufacturer's Declaration of Conformity for this apparatus, contact your local Agilent Technologies office or sales representative on [page 71](#).

## Statement of Compliance

This product has been designed and tested in accordance with IEC Publication 1010, Safety Requirements for Electronic Measuring Apparatus, and has been supplied in a safe condition. The instruction documentation contains information and warnings which must be followed by the user to ensure safe operation and to maintain the instrument in a safe condition.

## Warnings

---

**WARNING** The **WARNING** notice denotes a hazard. It calls attention to a procedure which if not correctly performed or adhered to, could result in personal injury. Do not proceed beyond a **WARNING** notice until the indicated conditions are fully understood and met.

---

Warnings applicable to this instrument are:

---

**WARNING** To prevent electrical shock, disconnect the Agilent Technologies model Z5623AH84 from mains before cleaning. Use a dry cloth or one slightly dampened with water to clean the external case parts. Do not attempt to clean internally.

---

---

**WARNING** If this product is not used as specified, the protection provided by the equipment could be impaired. This product must be used in a normal condition (in which all means for protection are intact) only.

---

---

**WARNING** For continued protection against fire hazard replace line fuse only with same type and rating:

- United States—F 0.5A/250V, Part Number 2110-0202
- Europe—F 3.15A/250V, Part Number 2110-0655

The use of other fuses or material is prohibited.

---

---

**WARNING** This is a Safety Class I product (provided with a protective earthing ground incorporated in the power cord). The mains plug shall be inserted only into a socket outlet provided with a protective earth contact. Any interruption of the protective conductor, inside or outside the product is likely to make the product dangerous. Intentional interruption is prohibited.

---

---

**WARNING** These servicing instructions are for use by qualified personnel only. To avoid electrical shock, do not perform any servicing unless you are qualified to do so.

---

---

**WARNING** The opening of covers or removal of parts is likely to expose dangerous voltages. Disconnect the instrument from all voltage sources while it is being opened.

---

---

**WARNING** This product is designed for use in Installation Category II and Pollution Degree 2 per IEC 61010-1: 2001.

---

---

**WARNING** No operator serviceable parts inside. Refer servicing to qualified personnel. To prevent electrical shock do not remove covers.

---

**WARNING** If this product is not used as specified, the protection provided by the equipment could be impaired. This product must be used in a normal condition (in which all means for protection are intact) only.

---

## Cautions

---

**CAUTION** The CAUTION notice denotes a hazard. It calls attention to an procedure that, if not correctly performed or adhered to, could result in damage to or destruction of the product. Do not proceed beyond a CAUTION notice until the indicated conditions are fully understood and met

---

Cautions applicable to this instrument are:

---

**CAUTION** Always use the three-prong ac power cord supplied with this instrument. Failure to ensure adequate earth grounding (by not using this cord) can cause instrument damage.

---

---

**CAUTION** This product is designed for use in Installation Category II and Pollution Degree 2 per IEC 61010-1:2001.

---

---

**CAUTION** This instrument has autoranging line voltage input; be sure the supply voltage is within the specified range.













---

---

**CAUTION** Ventilation Requirements: When installing the instrument in a cabinet, the convection into and out of the instrument must not be restricted. The ambient temperature (outside the cabinet) must be less than the maximum operating temperature of the instrument by 4 °C for every 100 watts dissipated in the cabinet. If the total power dissipated in the cabinet is greater than 800 watts, forced convection must be used.

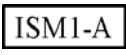
---

## Instrument Markings

	<p>When you see this symbol on your instrument, you should refer to the instrument's instruction manual for important information.</p>
	<p>This symbol indicates hazardous voltages.</p>
	<p>The laser radiation symbol is marked on products that have a laser output.</p>
	<p>This symbol indicates that the instrument requires alternating current (ac) input.</p>
	<p>The CE mark is a registered trademark of the European Community. If it is accompanied by a year, it indicates the year the design was proven.</p>
	<p>The CSA mark is a registered trademark of the Canadian Standards Association.</p>
	<p>This symbol indicates the product meets the Australian Standards.</p>
	<p>This symbol indicates separate collection for electrical and electronic equipment, mandated under EU law as of August 13, 2005. All electric and electronic equipment are required to be separated from normal waste for disposal (Reference WEEE Directive, 2002/96/EC).</p>
	<p>This text indicates that the instrument is an Industrial Scientific and Medical Group 1 Class A product (CISPR 11, Clause 4).</p>
	<p>This symbol indicates that the power line switch is ON.</p>
	<p>This symbol indicates that the power line switch is OFF or in STANDBY position.</p>
	<p>Safety Earth Ground. This is a Safety Class I product (provided with a protective earthing terminal). An uninterruptible safety earth ground must be provided from the main power source to the product input wiring terminals, power cord, or supplied power cord set. Whenever it is likely that the protection has been impaired, the product must be made inoperative and secured against any unintended operation.</p>

## Contacting Agilent

By internet, phone, or fax, get assistance with all your test and measurement needs.

This information supersedes all prior contact information.			
<b>Online assistance:</b> <a href="http://www.agilent.com/find/assist">www.agilent.com/find/assist</a>			
<b>Americas</b>			
<b>Brazil</b> (tel) (+55) 11 3351 7012 (fax) (+55) 11 3351 7024	<b>Canada</b> (tel) +1 877 894 4414 (fax) +1 303 662 3369	<b>Mexico</b> (tel) 1 800 254 2440 (fax) 1 800 254 4222	<b>United States</b> (tel) 800 829 4444 (alt) (+1) 303 662 3998 (fax) 800 829 4433
<b>Asia Pacific and Japan</b>			
<b>Australia</b> (tel) 1 800 225 574 (fax) 1 800 681 776 (fax) 1 800 225 539	<b>China</b> (tel) 800 810 0508 (alt) 800 810 0510 (fax) 800 810 0507 (fax) 800 810 0362	<b>Hong Kong</b> (tel) 800 933 229 (fax) 800 900 701	<b>India</b> (tel) 1600 112 626 (fax) 1600 112 727 (fax) 1600 113 040
<b>Japan (Bench)</b> (tel) 0120 32 0119 (alt) (+81) 426 56 7799 (fax) 0120 01 2144	<b>Japan (On-Site)</b> (tel) 0120 802 363 (alt) (+81) 426 56 7498 (fax) (+81) 426 60 8953	<b>Singapore</b> (tel) 1 800 275 0880 (fax) (+65) 6755 1235 (fax) (+65) 6755 1214	<b>South Korea</b> (tel) 080 778 0011 (fax) 080 778 0013
<b>Taiwan</b> (tel) 0800 047 669 (fax) 0800 047 667 (fax) 886 3492 0779	<b>Thailand</b> (tel) 1 800 2758 5822 (alt) (+66) 2267 5913 (fax) 1 800 656 336	<b>Malaysia</b> (tel) 1800 880 399 (fax) 1800 801 054	
<b>Europe</b>			
<b>Austria</b> (tel) 0820 87 44 11* (fax) 0820 87 44 22	<b>Belgium</b> (tel) (+32) (0)2 404 9340 (alt) (+32) (0)2 404 9000 (fax) (+32) (0)2 404 9395	<b>Denmark</b> (tel) (+45) 7013 1515 (alt) (+45) 7013 7313 (fax) (+45) 7013 1555	<b>Finland</b> (tel) (+358) 10 855 2100 (fax) (+358) (0) 10 855 2923
<b>France</b> (tel) 0825 010 700* (alt) (+33) (0)1 6453 5623 (fax) 0825 010 701*	<b>Germany</b> (tel) 01805 24 6333* (alt) 01805 24 6330* (fax) 01805 24 6336*	<b>Ireland</b> (tel) (+353) (0)1 890 924 204 (alt) (+353) (0)1 890 924 206 (fax) (+353) (0)1 890 924 024	<b>Israel</b> (tel) (+972) 3 9288 500 (fax) (+972) 3 9288 501
<b>Italy</b> (tel) (+39) (0)2 9260 8484 (fax) (+39) (0)2 9544 1175	<b>Luxemburg</b> (tel) (+32) (0)2 404 9340 (alt) (+32) (0)2 404 9000 (fax) (+32) (0)2 404 9395	<b>Netherlands</b> (tel) (+31) (0)20 547 2111 (alt) (+31) (0)20 547 2000 (fax) (+31) (0)20 547 2190	<b>Russia</b> (tel) (+7) 095 797 3963 (alt) (+7) 095 797 3900 (fax) (+7) 095 797 3901
<b>Spain</b> (tel) (+34) 91 631 3300 (alt) (+34) 91 631 3000 (fax) (+34) 91 631 3301	<b>Sweden</b> (tel) 0200 88 22 55* (alt) (+46) (0)8 5064 8686 (fax) 020 120 2266*	<b>Switzerland (French)</b> (tel) 0800 80 5353 opt. 2* (alt) (+33) (0)1 6453 5623 (fax) (+41) (0)22 567 5313	<b>Switzerland (German)</b> (tel) 0800 80 5353 opt. 1* (alt) (+49) (0)7031 464 6333 (fax) (+41) (0)1 272 7373
<b>Switzerland (Italian)</b> (tel) 0800 80 5353 opt. 3* (alt) (+39) (0)2 9260 8484 (fax) (+41) (0)22 567 5314	<b>United Kingdom</b> (tel) (+44) (0)7004 666666 (alt) (+44) (0)7004 123123 (fax) (+44) (0)7004 444555		
(tel) = primary telephone number; (alt) = alternate telephone number; (fax) = FAX number; * = in country number 11/16/04			

